

Wide Range of Two-circuit Switches; Select One for the Operating Environment/Application

- A wide selection of models are available, including the overtravel models with greater OT, indicator-equipped models for checking operation, low-temperature models, heat-resistant models, and corrosion-proof models.
 - Microload models are added to the product lineup.
 - Approved standards: EC/IEC, UL, CSA, CCC (Chinese standard).
- Contact your OMRON representative for information on approved models.



Be sure to read *Safety Precautions* on page 39 to 42 and *Safety Precautions for All Limit Switches*.

Features

Standard Models

Many Variations in Standard Limit Switches A Wide Range of Models

The WL Series provides a complete range of Limit Switches with a long history of meeting user needs. Select environment-resistant specifications, actuators for essentially any workpiece, operating sensitivity matched to the workpiece, operation indicators to aid operation and maintenance, and various wiring specifications.

Environment-resistant Models

Select from Six Types of Environment Resistance

The series includes Airtight Switches, Hermetic Switches, Heat-resistant Switches, Low-temperature Switches, Corrosion-proof switches, and Weather-proof Switches. Select the one required by the onsite environment.

Spatter-prevention Models

Excellent Performance on Arc Welding Lines or Sites with Spattering Cutting Powder Ideal for Welding Sites

Stainless steel and resins that resist adhesion of spatters are used to prevent troubles caused by zinc powder generated during welding.

Long-life Models

Mechanical Endurance of 30 Million Operations Long-life Models for High-frequency Applications

Long life has been achieved by increasing the resistance to friction and creating better sliding properties in the head mechanism. Greater visibility is provided when setting with a fluorescent display for setting the stroke.

Features Common to All Models

DPDB Operation

The double-pole, double-break structure ensures circuit braking.

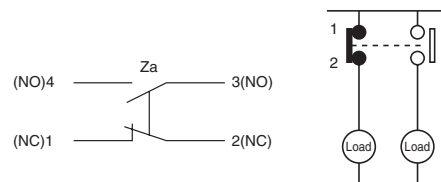

Degree of Protection; IP67

O-rings, cover seals, and other measures provide a water-proof, drip-proof structure (IP67).

Approved Standards to Aid Export Machines

Various WL/WLM switches are approved by UL, CSA, TÜV, EN/IEC, and CCC making them ideal for export machines.

High-precision Models Available in All Switch Types; Ideal for Position Control

High-precision models achieve a very small movement to operation (approx. 5°) and a repeat accuracy that is twice that of basic models.

Operation Indicators for Easier Daily Inspections*

Confirm operation with a neon lamp or LED for easier startup confirmations and maintenance.

* Operation indicators are provided on Indicator-equipped switches, Spatter-prevention Basic Switches, and Long-life Basic Switches.

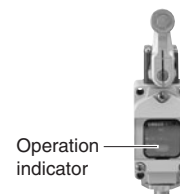

Models with Connectors to Reduce Wiring

Reduce wiring with one-touch connection. Models with direct-wired and prewired connectors that make Switch replacement easier are also available.

Product Configuration

Selection by Purpose

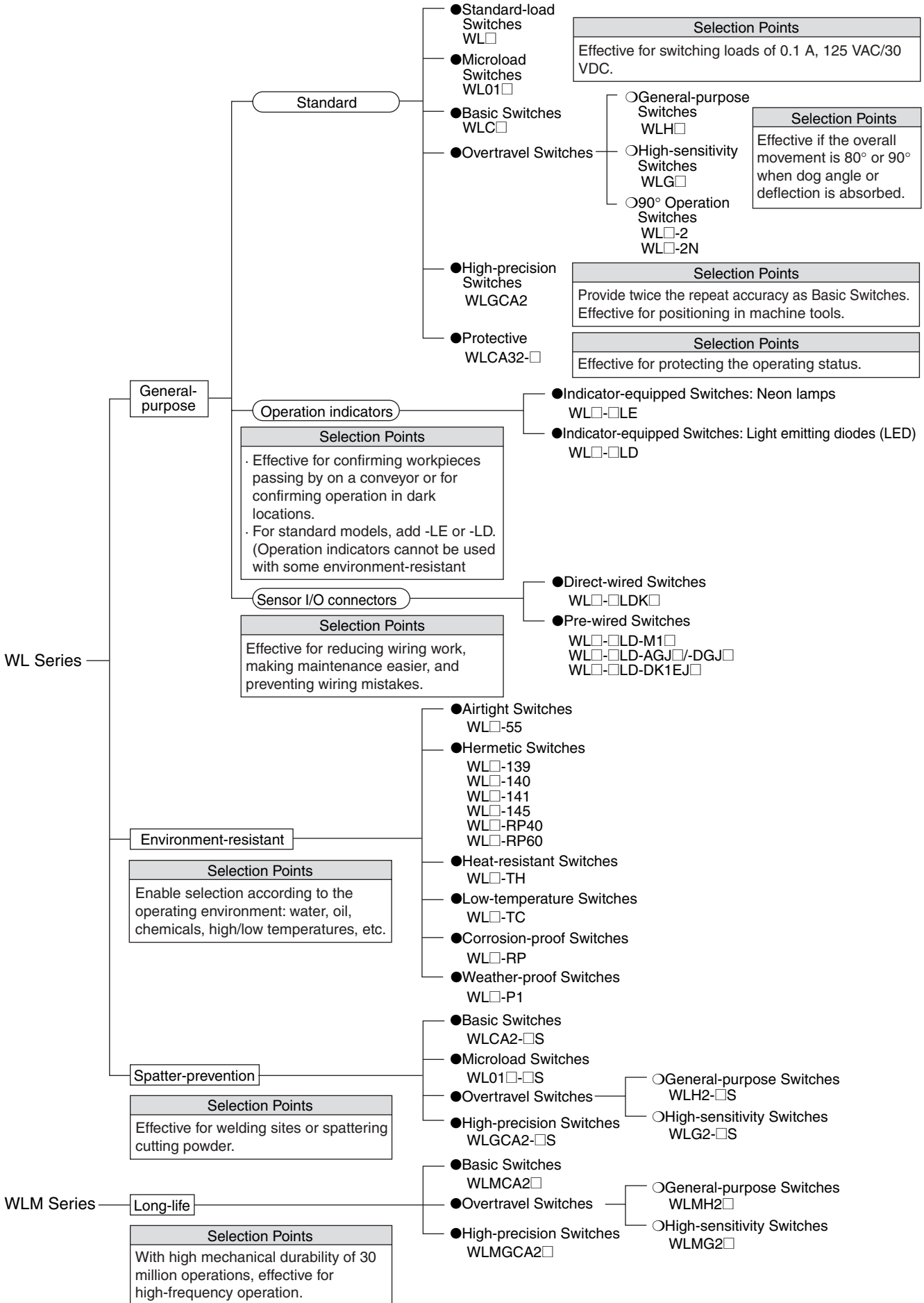

Tables of Models

General-purpose Switches

Spatter-prevention Switches

Long-life Switches

Heads (Roller levers only)

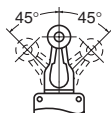
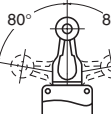
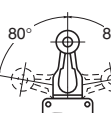
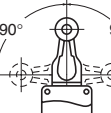
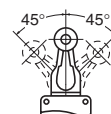
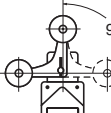
Type	General purpose	Features	Head specifications		Spatter prevention	Long-life
	Model		Total travel (TT)	One-side operation	Head mounting	Model
Basic	WLC□	<ul style="list-style-type: none"> With a Roller Lever 	Possible *1 (Except for long-life models.)	Any of 4 directions	WLCA2-□S	WLMCA2□
General-purpose Overtravel	WLH□	<ul style="list-style-type: none"> Overtravel is large, making setting the dog easier. Mounting is compatible with WLH2. 	Not possible *2	Any of 4 directions	WLH2-□S	WLH2□
High-sensitivity Overtravel	WLG□	<ul style="list-style-type: none"> Operation is highly sensitive with only 10° pretravel. Overtravel is large, making setting the dog easier. Mounting is compatible with WLG2. 	Not possible *2	Any of 4 directions	WLG2-□S	WLMG2□
Overtravel, 90° operation	WL□-2	<ul style="list-style-type: none"> Overtravel is large, making setting the dog easier. Mounting is compatible with WLCA2-2. 	Not possible *2	Any of 4 directions	—	—
	WL□-2N		Possible *1	Either of 2 directions		
High-precision	WLGCA2	<ul style="list-style-type: none"> Repeat accuracy is twice that basic models. Operation is highly sensitive with only 5° pretravel. Ideal for positioning, e.g., 	Possible *1	Any of 4 directions	WLGCA2-□S	WLMGCA2□
Maintained	WLCA32-□	<ul style="list-style-type: none"> When the dog throws the lever, the output is reversed and the reversed output is held even after the dog passed. The original status is returned to only after the dog passed. 	—	Any of 4 directions	—	—

*1. One-side operation means that three operational directions can be selected electrically, according to the change in direction of the operating plunger. The operating plunger is set for operation on both sides before delivery.

*2. Those models for which one-side operation is impossible can only operate on both sides.

Connectors and Conduits

Wiring type	General-purpose	Connector/conduit specifications	Spatter-prevention	Long-life
	Model		Model	Model
Direct-wired connector	WL□-□LDK□	• SC-2F/-4F Connector built-in	—	WLM□-LDK□
Pre-wired connector	WL□-□LD-M1□	• XS2H-series Pre-wired Connector built-in	WL□-□S-M1□J-1 WL□-□S-DGJS03	WLM□-LD-M1J
	WL□-□LD-□GJ□			WLM□-LD-□GJ□
	WL□-□LD-DK1EJ□			
Conduit (screw terminal)	WL□-□	<ul style="list-style-type: none"> G1/2 with no ground terminal G1/2 with ground terminal Pg13.5 with ground terminal M20 with ground terminal 1/2 14NPT with ground terminal 	—	WLM□-LD
	WL□-□G1□			—
	WL□-□G□			—
	WL□-□Y□			—
	WL□-□TS□			—

Environment-resistant Switches

Type	Item		Environment-resistant			
	Model	Application	Environment-resistant construction	Applicable models		
Airtight seal	WL□-55	For uses in locations subject to cutting oil or water	Uses the W-10FB3-55 Airtight Built-in Switch. Note: Use the SC Connector for the conduit opening.	All models except the low-temperature and heat-resistant models Note: Models can be produced using standard actuators.		
Hermetic seal (Molded terminals/ Anti-coolant)	WL□-139		Refer to page 25 for information on the environment-resistant construction of Switches with Hermetic Seals.		All models except the low-temperature and heat-resistant models Note: Models can be produced using standard actuators. Only the WLCA2, WLGCA2, or WLH2 can be produced for the WL□-141 and WL□-145.	
	WL□-140					
	WL□-141					
	WL□-145					
	WL□-RP40					
	WL□-RP60					
Low-temperature *	WL□-TC	Can be used at a temperature of -40°C (operating temperature range: -40 to 40°C), but cannot withstand icing.	<ul style="list-style-type: none"> • Uses a general-purpose built-in switch. • Silicone rubber is used for rubber parts such as the O-ring, gasket, etc. 	All models except airtight seal, hermetic seal, heat-resistant, corrosion-proof, and indicator-equipped models		
Heat-resistant *	WL□-TH	Can be used in temperatures of 120°C (operating temperature range: 5 to 120°C).	<ul style="list-style-type: none"> • Uses a special built-in switch made from heat-resistant resin. • Silicone rubber is used for rubber parts such as the O-ring, gasket etc. 	All models except airtight seal, hermetic seal, heat-resistant, corrosion-proof, and indicator-equipped, nylon roller (WLCA2-26N), seal roller models, and resin rod (WLNJ-2) models		
Corrosion-proof	WL□-RP	For use in locations subject to corrosive gases and chemicals.	<ul style="list-style-type: none"> • Diecast parts, such as the switch box, are made of corrosion-proof aluminum. • Rubber sealing parts are made of fluorine rubber which aids in resisting oil, chemicals and adverse weather conditions. • Exposed nuts and screws (except the actuator section) are made of stainless steel. • Moving and rotary parts such as rollers are made of sintered stainless steel or stainless steel. • The Head, box, and cover are yellow. 	All models except overtravel (90° operation), fork lever lock (WLCA32-41 to -43), low-temperature, heat-resistant, and indicator-equipped models		
Weather-proof *	WL□-P1	For use in parking lots and other outdoor locations.	<ul style="list-style-type: none"> • Rubber parts are made from silicone rubber, which has a high-tolerance to deterioration over time and changes in temperature. • Rollers are made of stainless steel to improve corrosion resistance. • Exposed nuts and screws are made of stainless steel. 	Only basic (WLCA2/CA12/CL), general-purpose overtravel (WLH2/H12/HL) and high-sensitivity overtravel (WLG2/G12/GL) models (excluding heat-resistant models).		

* Weather Resistance, Cold Resistance, and Heat Resistance



Silicon rubber is used to increase resistance to weather, cold, and heat. Silicon rubber, however, can generate silicon gas. (This can occur at room temperature, but the amount of silicon gas generated increases at higher temperatures.) Silicon gas will react as a result of arc energy and form silicon oxide (SiO₂). If silicon oxide accumulates on the contacts, contact interference can occur and can interfere with the device. Before using a Switch, test it under actual application conditions (including the environment and operating frequency) to confirm that no problems will occur in actual.

Selection Guide

With the WL Series, OMRON will combine the switch, Actuator, and wiring method required to build the ideal switch for your application.

The WL Series consists of four basic types: General-purpose, Environment-resistant, Spatter-prevention, and Long-life Switches. WLCA2 Switches can be used for the most common applications.

According to Operating Environment

	Environment	Key specifications	Models
Ambient operating temperature	Normal	<p style="text-align: center;">-10°C +80°C</p>  <p>Water-resistant to IP67.</p>	<p>WL□ General-purpose Switches</p> <p>WLM□ Long-life Switches</p>
	High-temperature	<p style="text-align: center;">+5°C +120°C</p>  <p>To increase heat resistance, the rubber material (silicon rubber) and the material of the built-in switch have been changed.</p>	<p>WL□-TH Heat-resistant Switches *1</p>
	Low-temperature	<p style="text-align: center;">-40°C +40°C</p>  <p>To increase resistance to cold, silicon rubber and other measures are used.</p>	<p>WL□-TC Low-temperature Switches *1</p>
Operating environment	Outdoors	Rubber parts are made from silicone rubber, which has a high-tolerance to deterioration over time and changes in temperature. Rollers are made of stainless steel to improve corrosion resistance. Exposed nuts and screws are made of stainless steel.	<p>WL□-P1 Weather-proof Switches *1</p>
	Chemicals and oil	Corrosion-proof aluminum diecast has been used for the housing, fluorine rubber has been used for rubber parts, and stainless steel has been used for screws and nuts (except for actuator) to increase resistance to oils, chemicals, and weather.	<p>WL□-RP Corrosion-proof Switches *1</p>
	Water drops and mist	Uses an airtight built-in switch.	<p>WL□-55 Airtight Switches *1</p>
	Constant water drops and mist	Cables attached. Uses a general-purpose built-in switch. The case cover and conduit opening are molded from epoxy resin to increase the seal. The cover cannot be removed.	<p>WL□-139 Hermetic, Molded-terminal Switches *1, *2</p>
		Cables attached. Uses an airtight built-in switch. The case cover and box interior are molded from epoxy resin to increase the seal. The cover cannot be removed. The SC connector can be removed, so it is possible to use flexible conduits for the cable.	<p>WL□-RP40 Hermetic, Molded-terminal Switches *1, *2</p>
		Cables attached. Uses an airtight built-in switch. The cover screws, case cover, box interior, and conduit opening are molded from epoxy resin to increase the seal. (The cover cannot be removed.)	<p>WL□-140 Hermetic, Molded-terminal Switches *1, *2</p>
	Constant water drops or splattering cutting powder	Cables attached. Uses an airtight built-in switch. The cover screws, case cover, box interior, conduit opening, box head, and head screws are molded from epoxy resin to increase the seal. (The cover cannot be removed.) The Head opening is protected from cutting powder. -141: The Head section is molded from epoxy resin; Head direction cannot be changed. -145: The Head section is molded from epoxy resin; Head can be in any of 4 directions.	<p>WL□-141, -145 Hermetic, Molded-terminal Switches *1, *2 (Only the WLCA2, WLG2, WLGA2, and WLH2 can be produced.)</p>
Coolant	Cables attached. Uses an airtight built-in switch. The case cover, box interior, conduit opening, and head screws are molded from epoxy resin to increase the seal. (The cover cannot be removed.) Rubber parts are made from fluorine rubber to increase resistance to coolant.	<p>WL□-RP60 Hermetic, Molded-terminal Switches *1, *2</p>	
Spattering from welding	To prevent spatter during welding, a heat-resistant resin is used for the indicator cover and screws and rollers are all made from stainless steel.	<p>WL□-S Spatter-prevention Switches</p>	

*1. Not all functions can be combined with environment-resistant switches. Refer to the applicable models on the previous page.

*2. Refer to page 25 for information on the construction of Hermetic Switches.











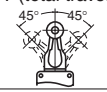

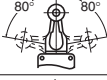

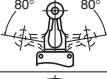

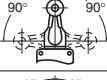

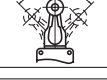







According to Application Conditions

	Conditions	Key specifications	Models	
Load	Switching standard loads	10 A at 125,250, or 500 VAC 0.8 A at 125 VDC 0.4 A at 250 VDC	WL□ WL□-S WLM□	General-purpose Switches Spatter-prevention Switches Long-life Switches
	Switching microloads	0.1 A at 125 VAC, resistive load 0.1 A at 30 VDC, resistive load	WL01□ WL01□-S	General-purpose Microload Switches Spatter-prevention Microload Switches
Durability	Normal durability	Mechanical: 15 million operation min. (10 million operation min. for overtravel general-purpose or high-sensitivity models or flexible rod models)	WL□ WL□-S	General-purpose Switches Spatter-prevention Switches
	Long-life	Mechanical: 30 million operation min.	WLM□	Long-life Switches

According to Ease of Installation and Maintenance

	Conditions	Key specifications	Models	
Operation indicator	Daily inspections and maintenance checks	Switching light-ON between operating/not operating. (Switching not possible for models with molded terminals.) Neon lamp 125 to 250 VAC	WL□-LE WL□-LES	General-purpose, Indicator-equipped (Neon Lamp) Switches Spatter-prevention, Indicator-equipped (Neon Lamp) Switches
		Switching light-ON between operating/not operating. (Switching not possible for models with molded terminals.) LED 10 to 115 VAC/DC	WL□-LD WL□-LDS	General-purpose, Indicator-equipped (LED) Switches Spatter-prevention, Indicator-equipped (LED) Switches
Wiring specification	Screw tightening and installation	Screw terminals. No ground terminal. Conduit size: G1/2	WL□ WLM□	General-purpose Switches Long-life Switches
		Screw terminals. Ground terminal. Conduit size: 4 sizes	WL□	General-purpose Switches
	One-touch connector attachment	Direct-wired connector, 2-conductor. Greatly reduces wiring work. Water-proof to IP67.	WL□-□LDK13 WLM□-LDK13	General-purpose, Direct-wired Connector Switches Long-life, Direct-wired Connector Switches
		Direct-wired connector, 4-conductor. Greatly reduces wiring work. Water-proof to IP67.	WL□-□LDK43 WLM□-LDK43	General-purpose, Direct-wired Connector Switches Long-life, Direct-wired Connector Switches
	Connector attachment in control and relay boxes	Pre-wired connector, 2-conductor. Greatly reduces wiring work. Water-proof to IP67.	WL□-□LD-M1J WL□-□S-M1J-1 WLM□-LD-M1J	General-purpose, Pre-wired Connector Switches Spatter-prevention, Pre-wired Connector Switches Long-life, Pre-wired Connector Switches
		Pre-wired connector, 4-conductor. Greatly reduces wiring work. Water-proof to IP67.	WL□-□LD-□GJO3 WL□-□S-□GJSO3 WLM□-LD-□GJO3	General-purpose, Pre-wired Connector Switches Spatter-prevention, Pre-wired Connector Switches Long-life, Pre-wired Connector Switches

According to Form of Operation

Detection object	Key specifications		Models	
Operation angles	General	TT (total travel)  PT (pretravel) 	WLCA2 WLCA2-□S WLMCA2	General-purpose Switches Spatter-prevention Switches Long-life Switches
	Passing dogs	 	WLH2 WLH2-□S WLMH2	General-purpose Switches Spatter-prevention Switches Long-life Switches
	Passing dogs, high sensitivity	 	WLG2 WLG2-□S WLMG2	General-purpose Switches Spatter-prevention Switches Long-life Switches
	Passing dogs	 WLCA2-2  WLCA2-2N 	WLCA2-2 WLCA2-2N	General-purpose Switches General-purpose Switches
	High precision	 	WLGCA2 WLGCA2-□S WLMGCA2	General-purpose Switches Spatter-prevention Switches Long-life Switches
Actuators	Dogs and workpieces (Mounts in any of 4 directions)	 <ul style="list-style-type: none"> ● Short lever ● One-Horizontal operation possible. (WLCA□ only) ● Head mounts in any of 4 directions. 	WL□2 WL□2-□S WLM□2	Roller Lever Actuators Roller Lever Actuators Roller Lever Actuators
		 <ul style="list-style-type: none"> ● Medium lever ● One-Horizontal operation possible. (WLCA□ only) ● Head mounts in any of 4 directions. 	WL□2-7	Roller Lever Actuators
		 <ul style="list-style-type: none"> ● Long lever ● One-Horizontal operation possible. (WLCA□ only) ● Head mounts in any of 4 directions. 	WL□2-8	Roller Lever Actuators
	Adjustable between dog and lever	 <ul style="list-style-type: none"> ● One-Horizontal operation possible. (WLCA□ only) ● Head mounts in any of 4 directions. 	WL□12	Adjustable Roller Lever Actuators
	Dogs or workpieces with large deflection	 <ul style="list-style-type: none"> ● One-Horizontal operation possible. (WLCL only) ● Head mounts in any of 4 directions. 	WL□L	Adjustable Rod Lever Actuators
		 <ul style="list-style-type: none"> ● One-Horizontal operation not possible. ● Head mounts in any of 4 directions. 	WLHAL4	Adjustable Rod Lever Actuator
		 <ul style="list-style-type: none"> ● One-Horizontal operation not possible. ● Head mounts in any of 4 directions. 	WLHAL5	Rod Spring Lever Actuator
	Round-trip operation of passing dogs	 <ul style="list-style-type: none"> ● Head mounts in any of 4 directions. 	WLCA32-41	Fork Lever Lock Actuator
		 <ul style="list-style-type: none"> ● Head mounts in any of 4 directions. 	WLCA32-42	Fork Lever Lock Actuator
		 <ul style="list-style-type: none"> ● Head mounts in any of 4 directions. 	WLCA32-43	Fork Lever Lock Actuator
 <ul style="list-style-type: none"> ● Head mounts in any of 4 directions. 		WLCA32-44	Fork Lever Lock Actuator	
Cams or workpieces with vertical movement		WLD	Top Plunger Actuator	
	 <ul style="list-style-type: none"> ● Head mounts in any of 4 directions. 	WLSD	Horizontal Plunger Actuator	
		WLD3	Top-ball Plunger Actuator	
	 <ul style="list-style-type: none"> ● Head mounts in any of 4 directions. 	WLSD3	Horizontal-ball Plunger Actuator	
	 <ul style="list-style-type: none"> ● Available in sealed models. (WLD28□) 	WLD2 WLD28	Top-roller Plunger Actuator Sealed Top-roller Plunger Actuator	
		WLSD2	Horizontal-roller Plunger Actuator	

Application Examples

Positioning on Production Lines

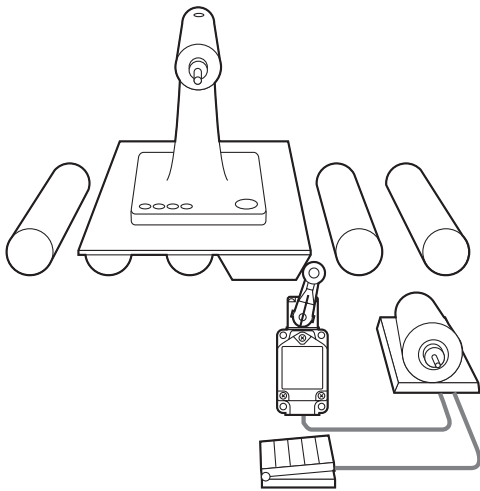

High-precision Positioning of Machine Tools

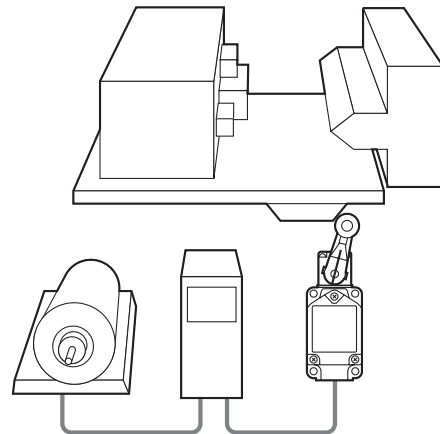

Positioning on Suspended Conveyors

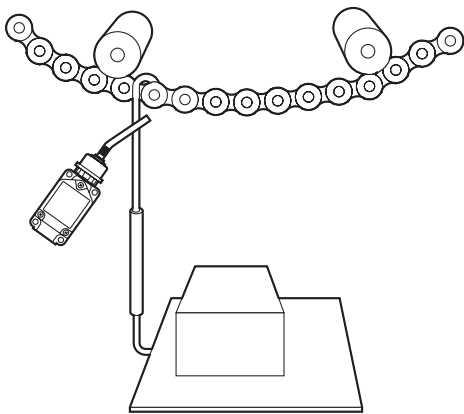

Pallet Detection in Arc Welding Lines

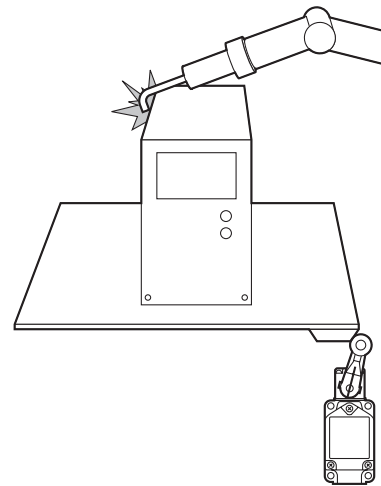

Multilevel Car Parking Towers

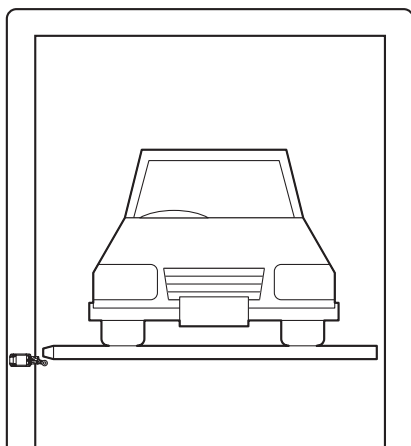

Limit Detection in Transport Systems

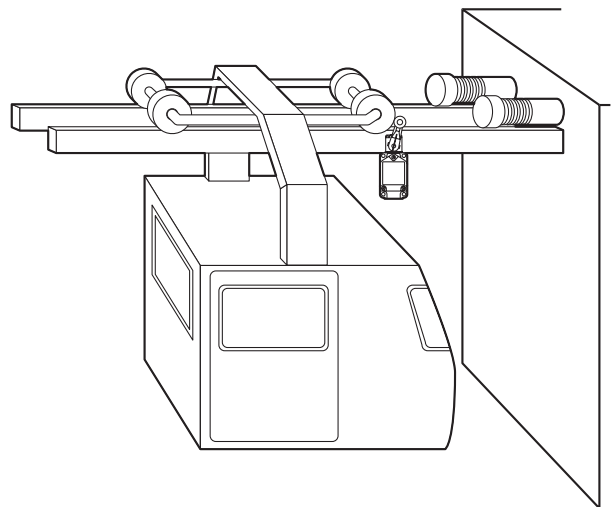

Model Number Structure

Model Number Legend (Not all combinations are possible. Ask your OMRON representative for details.)

General-purpose and Environment-resistant Switches

WL □□-□□□□□□□□
(1) (2) (3) (4) (5) (6) (7) (8) (9) (10)

(1) Electrical Rating

Blank	Standard load
01	Microload

Note: Dimensions are the same as the standard models.

(3) Environment-resistant Model Specifications

Blank	Standard
RP	Corrosion-proof *1
P1	Weather-proof *1

Note: Dimensions are the same as the standard models.

*1. Refer to page 4 for applicable models.

(4) Built-in Switch Type

Blank	Standard
55	Hermetically sealed *1

Note: Dimensions are the same as the standard models.

*1. Refer to page 4 for applicable models.

(5) Temperature Specifications

Blank	Standard: -10°C to +80°C
TH	Heat-resistant: +5°C to +120°C *1
TC	Low-temperature: -40°C to +40°C *1

Note: Dimensions are the same as the standard models.

*1. Refer to page 4 for applicable models.

(7) Conduit Size, Ground Terminal Specifications *2

Blank	G1/2 without ground terminal
G1	G1/2 with ground terminal
G	Pg13.5 with ground terminal
Y	M20 with ground terminal
TS	1/2-14NPT with ground terminal

Note: Dimensions are the same as the standard models.

*2. Models with ground terminals are approved by EN/IEC (CE marking).

(6) Hermetic Model Specifications

Blank	No cables or molding
139	General-purpose built-in switch with cables attached and molded conduit opening and cover (cover cannot be removed). *
140	Airtight built-in switch with cables attached and molded conduit opening, cover, and box interior cover screws (cover cannot be removed). *
141	Airtight built-in switch with cables attached and molded conduit opening, cover, head, box interior, cover screws, and head screws (cover cannot be removed, Head direction cannot be changed). The Head opening is created to protect it from cutting powder. *
145	Airtight built-in switch with cables attached and molded conduit opening, cover, box interior, and cover screws (cover cannot be removed, Head can be mounted in any of 4 directions). The Head opening is created to protect it from cutting powder. *
RP40	Airtight built-in switch with cables attached and molded cover and box interior (cover cannot be removed, Head direction can be changed). SC Connector can be removed, so it is possible to use flexible conduits for the cable. *
RP60	Airtight built-in switch with cables attached, fluorine rubber used, and molded conduit opening, cover, and box interior (cover cannot be removed, Head direction cannot be changed). *

* Refer to page 4 for applicable models.

(2) Actuator and Head Specifications

Symbol	Actuator type	Switch without lever
CA2	Roller lever: Standard model R38	WLCA2
CA2-7	Roller lever: Standard model R50	WLCA2
CA2-8	Roller lever: Standard model R63	WLCA2
H2	Roller lever: General-purpose overtravel model, 80°	WLRH2
G2	Roller lever: High-sensitivity overtravel, 80°	WLRG2
CA2-2	Roller lever: Overtravel, 90°	WLCA2-2
CA2-2N	Roller lever: Overtravel, 90°	WLCA2-2N
GCA2	Roller lever: High-precision R38	WLRGCA2
CA12	Adjustable roller lever: Standard	WLCA2
H12	Adjustable roller lever: General-purpose overtravel model, 80°	WLRH2
G12	Adjustable roller lever: High-sensitivity overtravel, 80°	WLRG2
CA12-2	Adjustable roller lever: Overtravel, 90°	WLCA2-2
CA12-2N	Adjustable roller lever: Overtravel, 90°	WLCA2-2N
CL	Adjustable rod lever: Standard, 25 to 140 mm	WLRCL
HL	Adjustable rod lever: General-purpose overtravel model, 80°, 25 to 140 mm	WLRH2
HAL4	Adjustable rod lever: General-purpose overtravel model, 80°, 350 to 380 mm	WLRH2
GL	Adjustable rod lever: High-sensitivity overtravel, 80°, 25 to 140 mm	WLRG2
CL-2	Adjustable rod lever: Overtravel, 90°, 25 to 140 mm	WLCA2-2
CL-2N	Adjustable rod lever: Overtravel, 90°, 25 to 140 mm	WLCA2-2N
HAL5	Rod spring lever: General-purpose overtravel model, 80°	WLRH2
CA32-41	Fork lever lock: Maintained, WL-5A100	WLCA32
CA32-42	Fork lever lock: Maintained, WL-5A102	WLCA32
CA32-43	Fork lever lock: Maintained, WL-5A104	WLCA32
D	Plunger: Top plunger	—
D2	Plunger: Top-roller plunger	—
D28	Plunger: Sealed top-roller plunger	—
D3	Plunger: Top-ball plunger	—
SD	Plunger: Horizontal plunger	—
SD2	Plunger: Horizontal-roller plunger	—
SD3	Plunger: Horizontal-ball plunger	—
NJ	Flexible rod: Coil spring	—
NJ-30	Flexible rod: Coil spring, multi-wire	—
NJ-2	Flexible rod: Coil spring, resin rod	—
NJ-S2	Flexible rod: Steel wire	—

(8) Indicator Type

Symbol	Element	Voltage	Leakage current
Blank	No indicator		
LE	Neon lamp	125 to 250 VAC	Approx. 0.6 to 1.9 mA
LD	LED	115 VAC/VDC	Approx. 0.5 mA
		10 to 24 VAC/VDC	Approx. 0.4 mA

Note: Dimensions are the same for both LE and LD models.

(9) Indicator Wiring

2	NC connection: Light-ON when operating
3	NO connection: Light-ON when not operating

Note: Include the indicator wiring specification only when a (6) hermetic seal and (8) operation indicator have been selected.

(10) Lever Type

Blank	Standard lever
A	Double nut lever

General-purpose Switches

Sensor I/O Connector Switches

WL □□-□□ LD □□
(1)(2)(3) (4) (5)

(1) Electrical Rating

Blank	Standard load
01	Microload

Note: Dimensions are the same as the standard models.

(2) Actuator Type

CA2	Roller lever: Standard model
GCA2	Roller lever: High-precision model
H2	Roller lever: General-purpose overtravel model
G2	Roller-lever: High-sensitivity overtravel model
D2	Top-roller plunger
D28	Sealed top-roller plunger

(3) Built-in Switch Type

Blank	Standard
55	Hermetically sealed

Note: Dimensions are the same as the standard models.

Spatter-prevention Switches

WL □□-□□ S □□
(1)(2) (3)(4) (5)

(1) Electrical Rating

Blank	Standard load
01	Microload

Note: Dimensions are the same as the standard models.

(2) Actuator Type

CA2	Roller lever: Standard model
GCA2	Roller lever: High-precision model
H2	Roller lever: General-purpose Overtravel model
G2	Roller lever: High-sensitivity Overtravel model
D28	Sealed top-roller plunger

(3) Built-in Switch Type

Blank	Standard
55	Hermetically sealed

Note: Dimensions are the same as the standard models.

(4) Indicator Type

LD	LED, AC/DC
LE	Neon lamp

Note: Dimensions are the same for both LE and LD models.

(5) Wiring Specifications

Blank	Screw terminal: G1/2 conduit
-M1J-1 *1	Pre-wired Connector *2 (2-conductor: DC, NO wiring, connector pins No. 3, 4)
-M1GJ-1 *1	Pre-wired Connector *2 (2-conductor: DC, NO wiring, connector pins No. 1, 4)
-DGJS03 *1	Pre-wired Connector *2 (4-conductor: DC)

*1. Models with pre-wired connectors and DC specifications are approved by EN/IEC (CE marking) except for LE Models (Neon Lamp Models).

*2. With 0.3-m cable attached.

Direct-wired Connector



Pre-wired Connector

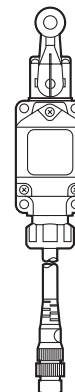

(4) Indicator Type

LD	LED, 10 to 115 VAC/DC
-----------	-----------------------

(5) Wiring Specifications

K13A	Direct-wired Connector (2-conductor: AC, NO wiring, connector pins No. 3, 4)
K13	Direct-wired Connector (2-conductor: DC, NO wiring, connector pins No. 3, 4)
K43A	Direct-wired Connector (4-conductor: AC)
K43	Direct-wired Connector (4-conductor: DC)
-M1J *1	Pre-wired Connector *2 (2-conductor: DC, NO wiring, connector pins No. 3, 4)
-M1GJ *1	Pre-wired Connector *2 (2-conductor: DC, NO wiring, connector pins No. 1, 4)
-M1JB	Pre-wired Connector *2 (2-conductor: DC, NC wiring, connector pins No. 3, 2)
-AGJ03	Pre-wired Connector *2 (4-conductor, AC)
-DGJ03 *1	Pre-wired Connector *2 (4-conductor, DC)
-DK1EJ03 *1	Pre-wired Connector *2 (3-conductor: DC, NO wiring, connector pins No. 2, 3, 4)

*1. Models with pre-wired connectors and DC specifications have EN/IEC approval (CE marking).

*2. With 0.3-m cable attached.

Long-life Switches

WLM□-LD□
(1) (2) (3)

(1) Actuator

CA2	Roller lever: Standard model
GCA2	Roller lever: High-precision model
H2	Roller lever: General-purpose overtravel model
G2	Roller lever: High-sensitivity overtravel model

(2) Indicator Type

LD	LED, 10 to 115 VAC/DC
-----------	-----------------------

(3) Wiring Specifications

Blank	Screw terminal: G1/2 conduit
K13A	Direct-wired Connector: 2-conductor, AC
K13	Direct-wired Connector: 2-conductor, DC
K43A	Direct-wired Connector: 4-conductor, AC
K43	Direct-wired Connector: 4-conductor, DC
-M1J	Pre-wired Connector: 2-conductor, DC *
-AGJ03	Pre-wired Connector: 4-conductor, AC *
-DGJ03	Pre-wired Connector: 4-conductor, DC *

* With 0.3-m cable attached.



Ordering Information





General-purpose Switches





Standard Switches

Note: Models are also available with ground terminals.





Lever



Item		Actuator	Roller lever R38 	Roller lever R50 	Roller lever R63 
			Model	Model	Model
Basic	Standard load		WLCA2	WLCA2-7	WLCA2-8
	Microload		WL01CA2	WL01CA2-7	WL01CA2-8
Overtravel	General-purpose	Standard load	WLH2	—	—
		Microload	WL01H2	—	—
	High-sensitivity	Standard load	WLG2	—	—
		Microload	WL01G2	—	—
	90° operation	Standard load	WLCA2-2	—	—
		Microload	WL01CA2-2	—	—
		Standard load	WLCA2-2N	—	—
		Microload	WL01CA2-2N	—	—
High-precision	Standard load	WLGCA2	—	—	
	Microload	WL01GCA2	—	—	

Item		Actuator	Adjustable roller lever 	Adjustable rod lever 25 to 140mm 	Adjustable rod lever 350 to 380mm 	Rod spring lever 
			Model	Model	Model	Model
Basic	Standard load		WLCA12	WLCL	—	—
	Microload		WL01CA12	WL01CL	—	—
Overtravel	General-purpose	Standard load	WLH12	WLHL	WLHAL4	WLHAL5
		Microload	WL01H12	WL01HL	—	—
	High-sensitivity	Standard load	WLG12	WLGL	—	—
		Microload	WL01G12	WL01GL	—	—
	90° operation	Standard load	WLCA12-2	WLCL-2	—	—
		Microload	WL01CA12-2	—	—	—
		Standard load	WLCA12-2N	WLCL-2N	—	—
		Microload	WL01CA12-2N	WL01CL-2N	—	—





Item		Actuator	Fork lever lock (with WL-5A100 plastic roller lever) 	Fork lever lock (with WL-5A102 plastic roller lever) 	Fork lever lock (with WL-5A104 plastic roller lever) 	Fork lever lock (with WL-5A104 plastic roller lever) 
			Model	Model	Model	Model
Maintained	Standard load		WLCA32-41	WLCA32-42	WLCA32-43	WLCA32-44
	Microload		WL01CA32-41	—	WL01CA32-43	WL01CA32-44

Plunger

Item		Actuator	Top plunger 	Top-roller plunger 	Top-ball plunger 	Sealed top-roller plunger 
			Model	Model	Model	Model
Top plunger	Standard load		WLD	WLD2	WLD3	WLD28
	Microload		WL01D	WL01D2	WL01D3	WL01D28

Item		Actuator	Horizontal plunger 	Horizontal-roller plunger 	Horizontal-ball plunger 
			Model	Model	Model
Side plunger	Standard load		WLS D	WLS D2	WLS D3
	Microload		WL01SD	WL01SD2	WL01SD3





Flexible Rod



Item		Actuator	Coil spring (spring diameter: 6.5) 	Coil spring (spring diameter: 4.8) 	Coil spring (resin rod diameter: 8) 	Steel wire (wire diameter: 1) 
			Model	Model	Model	Model
Flexible rod	Standard load		WLNJ	WLNJ-30	WLNJ-2	WLNJ-S2
	Microload		WL01NJ	WL01NJ-30	WL01NJ-2	WL01NJ-S2



General-purpose Switches

Indicator-equipped Switches





Lever



Item		Actuator	Roller lever R38 	Roller lever R50 	Roller lever R63 	Adjustable roller lever 
			Model	Model	Model	Model
Basic	Neon lamp		WLCA2-LE	WLCA2-7LE	WLCA2-8LE	WLCA12-LE
	LED		WLCA2-LD	WLCA2-7LD	WLCA2-8LD	WLCA12-LD
Overtravel	General-purpose	Neon lamp	WLH2-LE	—	—	WLH12-LE
		LED	WLH2-LD	—	—	WLH12-LD
	High-sensitivity	Neon lamp	WLG2-LE	—	—	WLG12-LE
		LED	WLG2-LD	—	—	WLG12-LD
	90° operation	Neon lamp	WLCA2-2LE	—	—	WLCA12-2LE
		LED	WLCA2-2LD	—	—	WLCA12-2LD
		Neon lamp	WLCA2-2NLE	—	—	WLCA12-2NLE
		LED	WLCA2-2NLD	—	—	WLCA12-2NLD
High-precision	Neon lamp	WLGCA2-LE	—	—	—	
	LED	WLGCA2-LD	—	—	—	

Item		Actuator	Adjustable rod lever 25 to 140 mm 	Adjustable rod lever 350 to 380 mm 	Rod spring lever 
			Model	Model	Model
Basic	Neon lamp		WLCL-LE	—	—
	LED		WLCL-LD	—	—
Overtravel	General-purpose	Neon lamp	WLHL-LE	WLHAL4-LE	WLHAL5-LE
		LED	WLHL-LD	WLHAL4-LD	WLHAL5-LD
	High-sensitivity	Neon lamp	WLGL-LE	—	—
		LED	WLGL-LD	—	—
	90° operation	Neon lamp	WLCL-2LE	—	—
		LED	WLCL-2LD	—	—
		Neon lamp	WLCL-2NLE	—	—
		LED	WLCL-2NLD	—	—





Item		Actuator	Fork lever lock (with WL-5A100 Plastic Roller Lever) 	Fork lever lock (with WL-5A102 Plastic Roller Lever) 	Fork lever lock (with WL-5A104 Plastic Roller Lever) 
			Model	Model	Model
Maintained	Neon lamp		WLCA32-41LE	WLCA32-42LE	WLCA32-43LE
	LED		WLCA32-41LD	—	WLCA32-43LD

Plunger

Item		Actuator	Top plunger 	Top-roller plunger 	Top-ball plunger 	Sealed top-roller plunger 
			Model	Model	Model	Model
Top plunger	Neon lamp		WLD-LE	WLD2-LE	WLD3-LE	WLD28-LE
	LED		WLD-LD	WLD2-LD	WLD3-LD	WLD28-LD

Item		Actuator	Horizontal plunger 	Horizontal-roller plunger 	Horizontal-ball plunger 
			Model	Model	Model
Side plunger	Neon lamp		WLSL-LE	WLSL2-LE	WLSL3-LE
	LED		WLSL-LD	WLSL2-LD	WLSL3-LD



Flexible Rod

Item		Actuator	Coil spring (spring diameter: 6.5) 	Coil spring (spring diameter: 4.8) 	Coil spring (resin rod diameter: 8) 	Steel wire (wire diameter: 1) 
			Model	Model	Model	Model
Flexible rod	Neon lamp		WLNJ-LE	WLNJ-30LE	WLNJ-2LE	WLNJ-S2LE
	LED		WLNJ-LD	WLNJ-30LD	WLNJ-2LD	WLNJ-S2LD



General-purpose Switches

Sensor I/O Connector Switches

Direct-wired Connectors

Actuator	Wiring				Item	Basic	Overtravel		High-precision
							General-purpose	High-sensitivity	
	Model	Model	Model	Model					
 Roller lever	2-conductor	DC	NO	connector pins No. 3, 4	Standard	WLCA2-LDK13	WLH2-LDK13	WLG2-LDK13	WLGCA2-LDK13
					Airtight seal	WLCA2-55LDK13	WLH2-55LDK13	WLG2-55LDK13	WLGCA2-55LDK13
	4-conductor	DC			Standard	WLCA2-LDK43	WLH2-LDK43	WLG2-LDK43	WLGCA2-LDK43
					Airtight seal	WLCA2-55LDK43	WLH2-55LDK43	WLG2-55LDK43	WLGCA2-55LDK43
 Top-roller plunger	2-conductor	DC	NO	connector pins No. 3, 4	Standard	WLD2-LDK13	—	—	—
					Airtight seal	WLD2-55LDK13	—	—	—
	4-conductor	DC			Standard	WLD2-LDK43	—	—	—
					Airtight seal	WLD2-55LDK43	—	—	—

Pre-wired Connectors

Actuator	Wiring				Item	Basic	Overtravel		High-precision
							General-purpose	High-sensitivity	
	Model	Model	Model	Model					
 Roller lever	2-conductor	DC	NO	connector pins No. 3, 4	Standard	WLCA2-LD-M1J	WLH2-LD-M1J	WLG2-LD-M1J	WLGCA2-LD-M1J
					Airtight seal	WLCA2-55LD-M1J	—	—	WLGCA2-55LD-M1J
				connector pins No. 1, 4	Standard	WLCA2-LD-M1GJ	WLH2-LD-M1GJ	WLG2-LD-M1GJ	WLGCA2-LD-M1GJ
			Airtight seal		WLCA2-55LD-M1GJ	—	WLG2-55LD-M1GJ	—	
			NC	connector pins No. 3, 2	Standard	—	—	WLG2-LD-M1JB	—
					Airtight seal	WLCA2-55LD-M1JB	—	WLG2-55LD-M1JB	WLGCA2-55LD-M1JB
	4-conductor	DC			Standard	WLCA2-LD-DGJ03	WLH2-LD-DGJ03	WLG2-LD-DGJ03	—
					Airtight seal	WLCA2-55LD-DGJ03	—	WLG2-55LD-DGJ03	WLGCA2-55LD-DGJ03
	3-conductor	DC		connector pins No. 2, 3, 4	Standard	WLCA2-LD-DK1EJ03	—	WLG2-LD-DK1EJ03	—
					Airtight seal	WLCA2-55LD-DK1EJ03	—	WLG2-55LD-DK1EJ03	—
 Top-roller plunger	2-conductor	DC	NO	connector pins No. 3, 4	Standard	WLD2-LD-M1J	—	—	—
					Airtight seal	WLD2-55LD-M1J	—	—	—
				connector pins No. 1, 4	Standard	WLD2-LD-M1GJ	—	—	—
			Airtight seal		WLD2-55LD-M1GJ	—	—	—	
			NC	connector pins No. 3, 2	Standard	—	—	—	—
					Airtight seal	WLD2-55LD-M1JB	—	—	—
	4-conductor	DC			Standard	WLD2-LD-DGJ03	—	—	—
					Airtight seal	—	—	—	—
	3-conductor	DC		connector pins No. 2, 3, 4	Standard	WLD2-LD-DK1EJ03	—	—	—
					Airtight seal	WLD2-55LD-DK1EJ03	—	—	—

Environment-resistant Switches

Note: Models are also available with ground terminals.

Item			Actuator	Roller lever R38 			
				Basic	Overtravel		
					General-purpose	High-sensitivity	
			Model	Model	Model		
Airtight seal			No indicator	WLCA2-55	WLH2-55	WLG2-55	
			Indicator	LED	WLCA2-55LD	WLH2-55LD	WLG2-55LD
				Neon	WLCA2-55LE	WLH2-55LE	WLG2-55LE
Hermetic seal	Molded terminals	-139	No indicator	WLCA2-139	WLH2-139	WLG2-139	
			Indicator	NC wiring	WLCA2-139LD2	—	—
				NO wiring	WLCA2-139LD3	—	WLG2-139LD3
		-140	No indicator	WLCA2-140	WLH2-140	WLG2-140	
			Indicator	NC wiring	WLCA2-140LD2	—	WLG2-140LD2
				NO wiring	WLCA2-140LD3	—	WLG2-140LD3
	-141	No indicator	WLCA2-141	WLH2-141	WLG2-141		
		Indicator	NC wiring	WLCA2-141LD2	—	WLG2-141LD2	
			NO wiring	WLCA2-141LD3	WLH2-141LD3	WLG2-141LD3	
	Anti-coolant		No indicator	WLCA2-RP60	WLH2-RP60	WLG2-RP60	
			Indicator	NC wiring	WLCA2-RP60LD2	—	WLG2-RP60LD2
				NO wiring	WLCA2-RP60LD3	WLH2-RP60LD3	WLG2-RP60LD3
Heat-resistant			No indicator	WLCA2-TH	WLH2-TH	WLG2-TH	
Low-temperature				WLCA2-TC	WLH2-TC	WLG2-TC	
Corrosion-proof				WLCA2-RP	WLH2-RP	WLG2-RP	
Weather-proof				WLCA2-P1	WLH2-P1	WLG2-P1	



Item			Actuator	Roller lever R38 			
				Overtravel		High-precision	
				90° (-2 model)	90° (-2N model)		
			Model	Model	Model		
Airtight seal			No indicator	WLCA2-255	WLCA2-2N55	WLGCA2-55	
			Indicator	LED	WLCA2-255LD	WLCA2-2N55LD	WLGCA2-55LD
				Neon	WLCA2-255LE	WLCA2-2N55LE	WLGCA2-55LE
Hermetic seal	Molded terminals	-139	No indicator	WLCA2-2139	WLCA2-2N139	WLGCA2-139	
			Indicator	NC wiring	WLCA2-2139LD2	—	WLGCA2-139LD2
				NO wiring	WLCA2-2139LD3	—	WLGCA2-139LD3
		-140	No indicator	—	WLCA2-2N140	WLGCA2-140	
			Indicator	NC wiring	—	—	WLGCA2-140LD2
				NO wiring	—	—	WLGCA2-140LD3
	-141	No indicator	—	—	WLGCA2-141		
		Indicator	NC wiring	—	—	—	
			NO wiring	—	—	WLGCA2-141LD3	
	Anti-coolant		No indicator	WLCA2-2RP60	—	WLGCA2-RP60	
			Indicator	NC wiring	WLCA2-2RP60LD2	—	WLGCA2-RP60LD2
				NO wiring	WLCA2-2RP60LD3	—	WLGCA2-RP60LD3
Heat-resistant			No indicator	WLCA2-2TH	WLCA2-2NTH	WLGCA2-TH	
Low-temperature				WLCA2-2TC	WLCA2-2NTC	WLGCA2-TC	
Corrosion-proof				—	—	WLGCA2-RP	

Actuator			Adjustable roller lever 			
			Basic	Overtravel		
				General-purpose	High-sensitivity	
Item			Model	Model	Model	
Airtight seal		No indicator	WLCA12-55	—	—	
		Indicator	LED	WLCA12-55LD	—	—
			Neon	WLCA12-55LE	—	—
Hermetic seal	Molded terminals	-139	WLCA12-139	—	—	
		-140	WLCA12-140	—	—	
		-141	WLCA12-141	—	—	
	Anti-coolant	WLCA12-RP60	—	—		
Heat-resistant		No indicator	WLCA12-TH	WLH12-TH	WLG12-TH	
Low-temperature			WLCA12-TC	WLH12-TC	WLG12-TC	
Corrosion-proof			WLCA12-RP	WLH12-RP	WLG12-RP	
Weather-proof			WLCA12-P1	WLH12-P1	WLG12-P1	



Actuator			Adjustable roller lever 	
			Overtravel	
			90° (-2 model)	90° (-2N model)
Item			Model	Model
Heat-resistant		No indicator	WLCA12-2TH	WLCA12-2NTH
Low-temperature			WLCA12-2TC	WLCA12-2NTC

Actuator			Adjustable rod lever 25 to 140 mm 			
			Basic	Overtravel		
				General-purpose	High-sensitivity	
Item			Model	Model	Model	
Airtight seal		No indicator	WLCL-55	—	—	
		Indicator	LED	WLCL-55LD	—	—
			Neon	—	—	—
Hermetic seal	Molded terminals	-139	WLCL-139	—	—	
		-140	WLCL-140	—	—	
		-141	—	—	—	
	Anti-coolant	WLCL-RP60	—	—		
Heat-resistant		No indicator	WLCL-TH	WLHL-TH	WLGL-TH	
Low-temperature			WLCL-TC	WLHL-TC	WLGL-TC	
Corrosion-proof			WLCL-RP	WLHL-RP	WLGL-RP	
Weather-proof			WLCL-P1	WLHL-P1	WLGL-P1	

Actuator			Adjustable rod lever 25 to 140 mm 	
			Overtravel	
			90° (-2 model)	90° (-2N model)
Item			Model	Model
Heat-resistant		No indicator	WLCL-2TH	WLCL-2NTH
Low-temperature			WLCL-2TC	WLCL-2NTC
Corrosion-proof			WLCL-2RP	—





Item			Actuator		Top-roller plunger 	Sealed top-roller plunger 	Horizontal plunger 
			No indicator		Model	Model	Model
Airtight seal	No indicator		LED		WLD2-55	WLD28-55	WLSD-55
			Neon		WLD2-55LD	WLD28-55LD	WLSD-55LD
	Indicator		Neon		WLD2-55LE	WLD28-55LE	—
Hermetic seal	Molded terminals	-139	No indicator		WLD2-139	WLD28-139	WLSD-139
		-140			—	WLD28-140	—
	Anti-coolant				WLD2-RP60	WLD28-RP60	WLSD-RP60
Heat-resistant			No indicator		WLD2-TH	WLD28-TH	WLSD-TH
Low-temperature					WLD2-TC	—	WLSD-TC
Corrosion-proof					WLD2-RP	WLD28-RP	WLSD-RP

Note: The standard cable length for models with airtight seals is 5 m.

Item			Actuator		Horizontal-roller plunger 	Coil spring (spring diameter: 6.5) 	Coil spring (resin rod diameter: 8) 
			No indicator		Model	Model	Model
Airtight seal	No indicator		LED		WLSD2-55	WLNJ-55	WLNJ-255
			Neon		WLSD2-55LD	WLNJ-55LD	WLNJ-255LD
	Indicator		Neon		—	—	—
Hermetic seal	Molded terminals	-139	No indicator		WLSD2-139	WLNJ-139	—
		-140			WLSD2-140	WLNJ-140	WLNJ-2140
	Anti-coolant				WLSD2-RP60	WLNJ-RP60	WLNJ-2RP60
Heat-resistant			No indicator		WLSD2-TH	WLNJ-TH	—
Low-temperature					WLSD2-TC	WLNJ-TC	WLNJ-2TC
Corrosion-proof					WLSD2-RP	WLNJ-RP	WLNJ-2RP



Note: The standard cable length for models with airtight seals is 5 m.

Spatter-prevention Switches

Actuator			Roller lever 		Sealed top-roller plunger 
			Double nut lever 	Allen-head lever 	
Item			Model	Model	Model
Neon lamp operation indicator	Basic		WLCA2-LEAS	WLCA2-LES	WLD28-LES
	Overtravel	General-purpose	WLH2-LEAS	WLH2-LES	—
		High-sensitivity	WLG2-LEAS	WLG2-LES	—
High-precision		—	WLGCA2-LES	—	
LED operation indicator	Basic		WLCA2-LDAS	WLCA2-LDS	WLD28-LDS
	Overtravel	General-purpose	WLH2-LDAS	WLH2-LDS	—
		High-sensitivity	WLG2-LDAS	WLG2-LDS	—
High-precision		—	WLGCA2-LDS	—	

Note: Ask your OMRON representative about WL01□□S Microload Switches.

Long-life Switches

Item			LED operation indicator *1			
			Basic	Overtravel		High-precision
Model	General-purpose	High-sensitivity		Model		
Actuator			Model	Model	Model	Model
 Roller lever, screw terminal			WLMCA2-LD	WLMH2-LD	WLMG2-LD	WLMGCA2-LD
 Roller lever, direct-wired connector	2-conductor	AC	WLMCA2-LDK13A	WLMH2-LDK13A	WLMG2-LDK13A	WLMGCA2-LDK13A
		DC	WLMCA2-LDK13	WLMH2-LDK13	WLMG2-LDK13	WLMGCA2-LDK13
	4-conductor	AC	WLMCA2-LDK43A	WLMH2-LDK43A	WLMG2-LDK43A	WLMGCA2-LDK43A
		DC	WLMCA2-LDK43	WLMH2-LDK43	WLMG2-LDK43	WLMGCA2-LDK43
 Roller lever, pre-wired connector *2	2-conductor	DC	WLMCA2-LD-M1J	WLMH2-LD-M1J	WLMG2-LD-M1J	WLMGCA2-LD-M1J
	4-conductor	DC	WLMCA2-LD-DGJ03	WLMH2-LD-DGJ03	WLMG2-LD-DGJ03	—



*1. The default setting is "light-ON when not operating."





Turn the lamp holder by 180° to change the setting to "light-ON when operating". (Ask your OMRON representative about 2-conductor models.)

*2. With 0.3-m cable attached.

Individual Parts









Heads

Actuator type	Set model	Head model (with Actuator)
Roller lever 	WLCA2	WL-1H1100
	WLG2	WL-2H1100
	WLH2	WL-2H1100-1 *
	WLCA2-2	WL-3H1100
	WLCA2-2N	WL-6H1100
Adjustable roller lever 	WLCA12	WL-1H2100
	WLG12	WL-2H2100
	WLH12	WL-2H2100-1 *
	WLCA12-2	WL-3H2100
Adjustable rod lever 	WLCL	WL-4H4100
	WGL	WL-2H4100
	WLCL-2	WL-3H4100
	WLCL-2N	WL-6H4100

Actuator type	Set model	Head model (with Actuator)
Top plunger 	WLD	WL-7H100
	WLD2	WL-7H200
	WLD3	WL-7H300
	WLD28	WL-7H400
Horizontal plunger 	WLS	WL-8H100
	WLS2	WL-8H200
	WLS3	WL-8H300
Fork lever lock 	WLCA32-41	WL-5H5100
	WLCA32-42	WL-5H5102
	WLCA32-43	WL-5H5104
	WLCA32-44	WL-5H5104
Coil spring 	WLNJ	WL-9H100
	WLNJ-30	WL-9H200
	WLNJ-2	WL-9H300
	WLNJ-S2	WL-9H400

* The model number of Heads without levers are same as those of Heads with levers without the numbers at the end.
 Example: WL-1H1100 becomes WL-1H without the lever.
 However, the WLH2 and WLH12 become WL-2H-1 and the WLGCA2 becomes WL-1H-1 for the Heads without levers.
 Other Heads are also available. Ask your OMRON representative.

Switches without levers



Actuator type	Switches without levers 	
	Model	
Switches for roller levers 	Basic R38	WLRCA2
	High-precision R38	WLRGCA2
	High-sensitivity overtravel, 80°	WLRG2
	General-purpose overtravel, 80°	WLRH2
	Overtravel, 90° operation	WLRCA2-2
	Overtravel, 90° operation	WLRCA2-2N
Switches for adjustable roller levers 	Basic	WLRCA2
	High-sensitivity overtravel, 80°	WLRG2
	General-purpose overtravel, 80°	WLRH2
	Overtravel, 90° operation	WLRCA2-2
	Overtravel, 90° operation	WLRCA2-2N
Switches for adjustable rod lever 	Basic, 25 to 140 mm	WLRCL
	High-sensitivity overtravel, 80°, 25 to 140 mm	WLRG2
	Overtravel, 90° operation, 25 to 140 mm	WLRCA2-2
	Overtravel, 90° operation, 25 to 140 mm	WLRCA2-2N
Switches for top plungers 	—	—
Switches for horizontal plungers 	—	—
Switches for fork lever locks 	Maintained, WL-5A100 Maintained, WL-5A102 Maintained, WL-5A104	WLRCA32
Switches for coil springs 	—	—

Covers with Operation Indicators



Cover	Cover only with indicator 	
	Model	
Item		
Neon lamp	WL-LE	
LED	WL-LD	

Note: The default setting is "light-ON when not operating."
 Turn the lamp holder by 180° to change the setting to "light-ON when operating."



**Spatter-prevention Products
Head (with actuator)**

Complete Heads with allen-head levers 	Double Nut Lever 
Model	Model
WL-1H1100S (for WLCA2-□ or WLGCA2-□)	WL-2H1100S (for WLH2-□ or WLG2-□)

Lever

Allen-head Lever 	Double Nut Lever 
Model	Model
WL-1A103S Roller lever	WL-1A105S Roller Lever

Cover with indicator Switches without Levers

Cover with Indicator 	Switches without levers 
Model	Model
Neon lamp WL-LES	WLRCA2-LDS
LED (LED) WL-LDS	WLRH2-LES WLRH2-LDS
	WLRG2-LDS WLRGCA2-LES

WL Head Replacement

Heads can be replaced within the same model group. They cannot be replaced between different model groups.

Group No.	Set model number	Head model number (with Actuator)
1	WLCA2	WL-1H1100
	WLCA2-7	WL-1H1200
	WLCA2-8	WL-1H1300
	WLCA12	WL-1H2100
2	WLCL	WL-4H4100 *
3	WLH2	WL-2H1100-1
	WLH12	WL-2H2100-1
	WLHL	WL-2H4100
	WLHAL4	WL-2H4106
	WLHAL5	WL-2H4107
4	WLCA2-2N	WL-6H1100
	WLCA12-2N	WL-6H2100
	WLCL-2N	WL-6H4100
5	WLCA2-2	WL-3H1100
	WLCA12-2	WL-3H2100
	WLCL-2	WL-3H4100
6	WLG2	WL-2H1100
	WLG12	WL-2H2100
	WGL	WL-2H4100
7	WLCA32-41	WL-5H5100
	WLCA32-42	WL-5H5102
	WLCA32-43	WL-5H5104
	WLCA32-44	WL-5H5104
8	WLD	WL-7H100
	WLD2	WL-7H200
	WLD3	WL-7H300
9	WLD28	WL-7H400 *
10	WLS	WL-8H100
	WLS2	WL-8H200
	WLS3	WL-8H300
11	WLNJ	WL-9H100
	WLNJ-30	WL-9H200
12	WLNJ-2	WL-9H300 *
13	WLNJ-S2	WL-9H400 *

* This Heads are special and must be used. Do not use any other Head.

Specifications

Approved Standards

Agency	Standard	File No.	Approved models
UL	UL508	E76675	Contact your OMRON representative for information on approved models.
CSA	CSA C22.2 No.14	LR45746	
TÜV Rheinland	EN60947-5-1	J50022353, J9950023, J9950959	
CCC (CQC)	GB14048.5	2004010305128675	

General-purpose/Weather-proof Switches

Ratings

Standard-load Switches

Item Model	Rated voltage (V)	Non-inductive load (A)				Inductive load (A)			
		Resistive load		Lamp load		Inductive load		Motor load	
		NC	NO	NC	NO	NC	NO	NC	NO
Basic models, overtravel models (except for high-sensitivity models), and high-precision models	125 VAC	10	3	1.5	10	5	2.5		
	250 VAC	10	2	1	10	3	1.5		
	500 VAC	10	1.5	0.8	3	1.5	0.8		
	8 VDC	10	6	3	10	6			
	14 VDC	10	6	3	10	6			
High-sensitivity overtravel models	30 VDC	6	4	3	6	4			
	125 VDC	0.8	0.2	0.2	0.8	0.2			
	250 VDC	0.4	0.1	0.1	0.4	0.1			
	125 VAC	5	—	—	—	—			
	250 VAC	5	—	—	—	—			
High-sensitivity overtravel models	125 VDC	0.4	—	—	—	—			
	250 VDC	0.2	—	—	—	—			

Inrush current	NC	30 A max. (15 A max. *)
	NO	20 A max. (10 A max. *)

- Note: 1. The above figures are for steady-state currents.
 2. Inductive loads have a power factor of 0.4 min. (AC) and a time constant of 7 ms max. (DC).
 3. A lamp load has an inrush current of 10 times the steady-state current.
 4. A motor load has an inrush current of 6 times the steady-state current.
 5. For PC loads, use the microload models.

* For high-sensitivity overtravel models.

Minimum applicable load	5 VDC 160 mA
-------------------------	--------------

Microload Switches (Refer to these ratings before using the product.)

Rated voltage (V)	Rated current (A) - Resistive load
AC 125	0.1
DC 30	

Operation in the following ranges will produce optimum performance.

Recommended load range	5 to 30 VDC 0.5 to 100 mA
------------------------	------------------------------

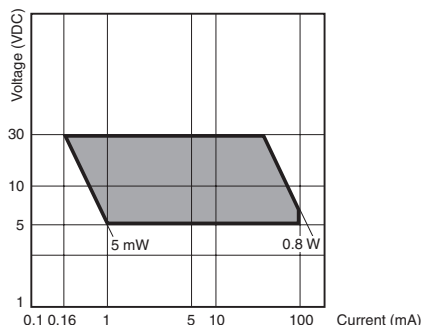

Recommended load range	5 VDC 1 mA
------------------------	------------

Approved Standard Ratings

UL/CSA

Standard-load Switches: A600, NEMA

Rated voltage	Carry current	Current (A)		Volt-amperes (VA)	
		Make	Break	Make	Break
120 VAC	10 A	60	6	7,200	720
240 VAC		30	3		
480 VAC		15	1.5		
600 VAC		12	1.2		

Microload Switches

0.1 A 125 VAC, 0.1 A 30 VDC

TÜV (EN60947-5-1) (Only models with ground terminals are approved.)

Model	Application category and ratings	Thermal current (I _{the})	Indicator
WL□	AC-15: 2 A/250 V DC-12: 2 A/48 V	10 A	—
WL01□	AC-14: 0.1 A/125V DC-12: 0.1 A/48 V	0.5 A	—
WL□-LE	AC-15: 2 A/250 V	10 A	Neon lamp
WL01□-LE	AC-14: 0.1 A/125 V	0.5 A	Neon lamp
WL□-LD	AC-15: 2 A/115 V DC-12: 2 A/48 V	10 A	LED
WL01□-LD	AC-14: 0.1 A/115 V DC-12: 0.1 A/48 V	0.5 A	LED

Note: As an example, AC-15: 2 A/250 V means the following:

Application category	AC-15
Rated operating current (I _e)	2A
Rated operating voltage (U _e)	250V

Indicator-equipped Switches

Model	Item	Max. rated voltage (V)	Leakage current (mA)
WL-LE	Neon lamp	125 AC	Approx. 0.6
		250 AC	Approx. 1.9
WL-LD	LED	115 AC/DC	Approx. 0.5
		10 to 24 AC/DC	Approx. 0.4

Characteristics

Degree of protection	IP67	
Durability *1	Mechanical	15,000,000 operations min. *2
	Electrical	750,000 operations min. *3
Operating speed	1 mm/s to 1 m/s (in case of WLCA2)	
Operating frequency	Mechanical	120 operations/minute min.
	Electrical	30 operations/minute min.
Rated frequency	50/60 Hz	
Insulation resistance	100 MΩ min. (at 500 VDC)	
Contact resistance	25 mΩ max. (initial value for the built-in switch when tested alone) *6	
Dielectric strength	Between terminals of the same polarity	1,000 VAC (600 VAC), 50/60 Hz for 1 min
	Between current-carrying metal part and ground	2,200 VAC (1,500 VAC), 50/60 Hz for 1 min/Uimp 2.5 kV
	Between each terminal and non-current-carrying metal part	2,200 VAC (1,500 VAC), 50/60 Hz for 1 min/Uimp 2.5 kV
Rated insulation voltage (U _i)	250 V (EN60947-5-1)	
Pollution degree (operating environment)	3 (EN60947-5-1)	
Short-circuit protective device (SCPD)	10 A, fuse type gG or gI (IEC60269)	
Conditional short-circuit current	100 A (EN60947-5-1)	
Conventional enclosed thermal current (I _{the})	10 A, 0.5 A (EN60947-5-1)	
Protection against electric shock	Class I	
Vibration resistance	Malfunction	10 to 55 Hz, 1.5-mm double amplitude *4
Shock resistance	Destruction	1,000 m/s ² min.
	Malfunction	300 m/s ² min. *4
Ambient operating temperature	-10°C to +80°C (with no icing) *5	
Ambient operating humidity	35% to 95% RH	
Weight	Approx. 275 g (in case of WLCA2)	

Note: 1. The above figures are initial values.

2. The figures in parentheses for dielectric strength are those for the high-sensitivity overtravel models.

- *1. The values are calculated at an operating temperature of +5°C to +35°C and an operating humidity of 40% to 70%RH. Contact your OMRON sales representative for more detailed information on other operating environments.
- *2. Durability is 10,000,000 operations min. for general-purpose or high-sensitivity overtravel models, and for flexible rod models. 500,000 operations min. for weather-proof models.
- *3. Durability is 500,000 operations min. for high-sensitivity models. All microload models are 1,000,000 operations min. 500,000 operations min. for weather-proof models.
- *4. Except flexible rod models. The shock resistance (malfunction) for microload models is 200 m/s² min.
- *5. For low-temperature models this is -40°C to +40°C (with no icing). For heat-resistant models the range is +5°C to +120°C.
- *6. For microload models, the contact resistance is 50 mΩ max. (initial value for built-in switch).

Spatter-prevention Switches

Ratings

Screw terminals

Item	Rated voltage (V)	Non-inductive load (A)			Inductive load (A)				
		Resistive load		Lamp load	Inductive load		Motor load		
		NC	NO	NC	NO	NC	NO	NC	NO
WL□-LES	125 VAC	10	3	1.5	10	5	2.5		
	250 VAC	10	2	1	10	3	1.5		
WL□-LDS	115 VAC	10	3	1.5	10	5	2.5		
	12 VDC	10	6	3	10	6			
	24 VDC	6	4	3	6	4			
	48 VDC	3	2	1.5	3	2			

Note: 1. The above figures are for steady-state currents.

2. Inductive loads have a power factor of 0.4 min. (AC) and a time constant of 7 ms max. (DC).

3. A lamp load has an inrush current of 10 times the steady-state current.

4. A motor load has an inrush current of 6 times the steady-state current.

Inrush current	NC	30 A max.
	NO	20 A max.
Operating temperature	-10°C to +80°C (with no icing)	
Operating humidity	35% to 95%RH max.	

Approved Standard Ratings

UL/CSA

LE Switches (Neon lamp): A300

Rated voltage	Carry current	Current (A)		Volt-amperes (VA)	
		Make	Break	Make	Break
120 VAC	10 A	60	6	7,200	720
240 VAC		30	3		

LD Switches (LED)

Rated voltage	Carry current
115 VAC	10 A
115 VDC	0.8 A

CCC (GB14048.5)

Model	Application category and ratings
WL□	AC-15: 2 A/250 V DC-12: 2 A/48 V
WL01□	AC-14: 0.1 A/125V DC-12: 0.1 A/48 V
WL□-LE	AC-15: 2 A/250 V
WL01□-LE	AC-14: 0.1 A/125 V
WL□-LD	AC-15: 2 A/115 V DC-12: 2 A/48 V
WL01□-LD	AC-14: 0.1 A/115 V DC-12: 0.1 A/48 V

Note: As an example, AC-15: 2 A/250 V means the following:

Application category	AC-15
Rated operating current (Ie)	2 A
Rated operating voltage (Ue)	250 V

Characteristics

Degree of protection	IP67	
Durability *1	Mechanical	15,000,000 operations min. *2
	Electrical	750,000 operations min. *3
Operating speed	1 mm/s to 1 m/s (in case of WLCA2)	
Operating frequency	Mechanical	120 operations/minute min.
	Electrical	30 operations/minute min.
Rated frequency	50/60 Hz	
Insulation resistance	100 MΩ min. (at 500 VDC)	
Contact resistance	25 mΩ max. (initial value for the built-in switch when tested alone)	
Dielectric strength	Between terminals of the same polarity	1,000 VAC (600 VAC), 50/60 Hz for 1 min
	Between current-carrying metal part and ground	2,200 VAC (1,500 VAC), 50/60 Hz for 1 min/Uimp 2.5 kV
	Between each terminal and non-current-carrying metal part	2,200 VAC (1,500 VAC), 50/60 Hz for 1 min/Uimp 2.5 kV
Rated insulation voltage (Ui)	250 V (EN60947-5-1)	
Pollution degree (operating environment)	3 (EN60947-5-1)	
Short-circuit protective device (SCPD)	10 A, fuse type gG or gI (IEC60269)	
Conditional short-circuit current	100 A (EN60947-5-1)	
Conventional enclosed thermal current (Ithe)	10 A, 0.5 A (EN60947-5-1)	
Protection against electric shock	Class I	
Vibration resistance	Malfuction	10 to 55 Hz, 1.5-mm double amplitude
Shock resistance	Destruction	1,000 m/s ² min.
	Malfuction	300 m/s ² min.
Ambient operating temperature	-10°C to +80°C (with no icing)	
Ambient operating humidity	35% to 95%RH	
Weight	Approx. 275 g (in case of WLCA2)	

Note: 1. The above figures are initial values.

2. The figures in parentheses for dielectric strength are those for the high-sensitivity overtravel models.

*1. The values are calculated at an operating temperature of +5°C to +35°C and an operating humidity of 40% to 70%RH. Contact your OMRON sales representative for more detailed information on other operating environments.

*2. Durability is 10,000,000 operations min. for general-purpose or high-sensitivity overtravel models.

*3. Durability is 500,000 operations min. for high-precision models. All microload models however, are 1,000,000 operations min.

Long-life Switches

Ratings

General Ratings (Refer to these ratings before using the product.)

Screw Terminal Switches

Item Model	Rated voltage (V)	Non-inductive load (A)				Inductive load (A)			
		Resistive load		Lamp load		Inductive load		Motor load	
		NC	NO	NC	NO	NC	NO	NC	NO
Basic models, overtravel models, (except for high-sensitivity models), and high-precision models	115 AC	10	3	1.5	10	5	2.5		
	12 DC	10	6	3	10	6			
	24 DC	6	4	3	6	4			
	48 DC	3	2	1.5	3	2			
	115 DC	0.8	0.2	0.2	0.8	0.2			
High-sensitivity overtravel models	115 AC	5	—	—	—	—			
	115 DC	0.4	—	—	—	—			

Inrush current	NC	30 A max. (15 A max. *)
	NO	20 A max. (10 A max. *)

* For high-sensitivity overtravel models.

Direct-wired Connector and Pre-wired Connector Switches

Model	Rated voltage (V)	Non-inductive load (A)				Inductive load (A)			
		Resistive load		Lamp load		Inductive load		Motor load	
		NC	NO	NC	NO	NC	NO	NC	NO
DC	12 DC	3	3	3	3	3	3	3	3
	24 DC	3	3	3	3	3	3	3	3
	48 DC	3	3	3	3	3	3	3	3
	115 DC	0.8	0.8	0.2	0.2	0.8	0.8	0.2	0.2
	AC	115 AC	3	3	3	1.5	3	3	3

- Note: 1. The above figures are for steady-state currents.
 2. Inductive loads have a power factor of 0.4 min. (AC) and a time constant of 7 ms max. (DC).
 3. A lamp load has an inrush current of 10 times the steady-state current.
 4. A motor load has an inrush current of 6 times the steady-state current.

Characteristics

Degree of protection		IP67
Durability *	Mechanical	30,000,000 operations min.
	Electrical	30,000,000 operations min. (10 mA at 24 VDC, resistive load) 750,000 operations min. (10 A at 115 VAC, resistive load), but for high-precision models: 500,000 operations min. (10 A at 115 VAC, resistive load)
Operating speed		1 mm/s to 1 m/s (in case of WLCA2)
Operating frequency	Mechanical	120 operations/minute
	Electrical	30 operations/minute
Rated frequency		50/60 Hz
Insulation resistance		100 MΩ min. (at 500 VDC)
Contact resistance		25 mΩ max. (initial value for the built-in switch when tested alone)
Dielectric strength (50/60 Hz for 1 min)	Between terminals of the same polarity	1,000 VAC (except connector models)
	Between current-carrying metal part and ground	2,200 VAC (1,500 V)
	Between each terminal and non-current-carrying metal part	2,200 VAC (1,500 V)
Vibration resistance	Malfunction	10 to 55 Hz, 1.5-mm double amplitude
Shock resistance	Destruction	1,000 m/s ² min.
	Malfunction	300 m/s ² min.
Ambient operating temperature		-10°C to +80°C (with no icing)
Ambient operating humidity		35% to 95%RH
Weight		Approx. 275 g (in case of WLCA2)

Note: The figures in parentheses for dielectric strength, are those for overtravel (high-sensitivity) or connector models.

* The values are calculated at an operating temperature of +5°C to +35°C, and an operating humidity of 40% to 70%RH. Contact your OMRON sales representative for more detailed information on other operating environments.

Engineering Data

Electrical Durability: $\cos\phi=1$

(Operating temperature: +5°C to +35°C, operating humidity: 40% to 70%RH)

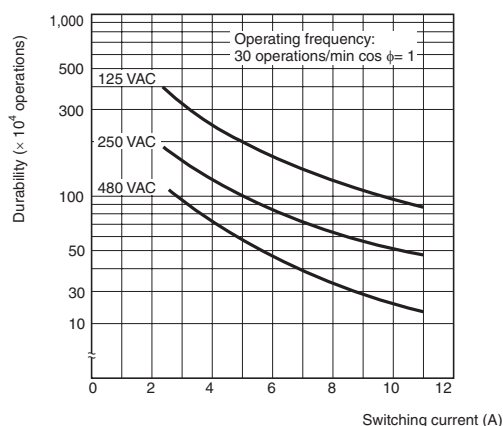

Structure and Nomenclature

Structure

General-purpose Switches: WLCA2

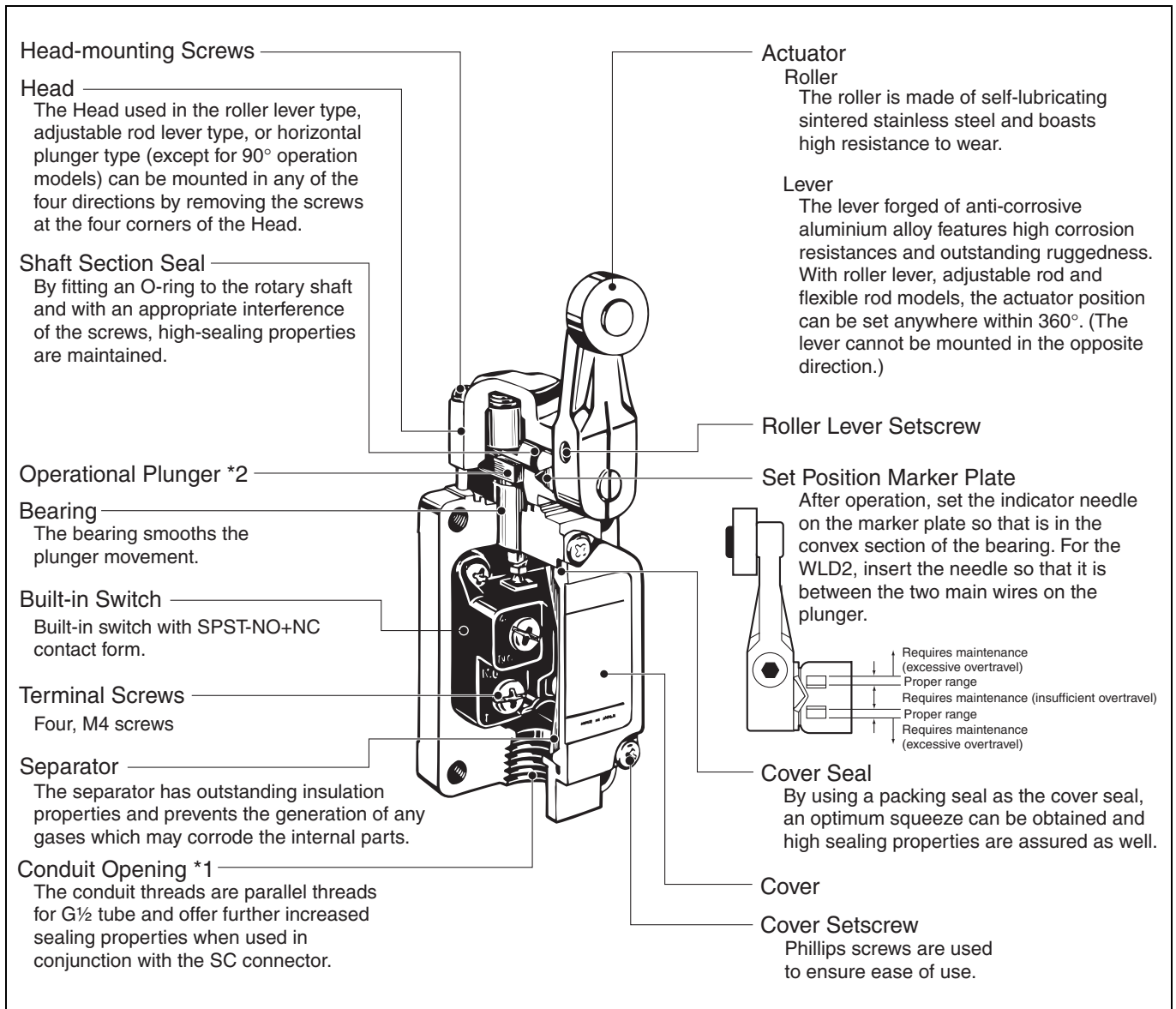

*1. The display for conduit threads has changed from PF $\frac{1}{2}$ to G $\frac{1}{2}$, according to revisions of JIS B 0202. This is only a change in the display, so the thread size and pitch have not changed. (Conduit threads Pg 13.5 and $\frac{1}{2}$ -14NPT are also available.)

*2. By changing the orientation of the operational plunger, any one of the three operational directions (both sides, left, or right) can be selected electrically.

Indicators

Indicator Covers

The indicator covered if outsert molded from diecast aluminum and has outstanding sealing properties.

Indicator Windows

Operation (i.e., light-ON when operating or light-ON when not operating) depends on whether a neon lamp or LED is used.

Light-ON when Operating/Not Operating

Indicators can be switched from light-ON when operating and light-ON when not operating, by simply rotating the indicator holder by 180°. (Molded terminals cannot be switched in this way.)

Light-ON when Operating

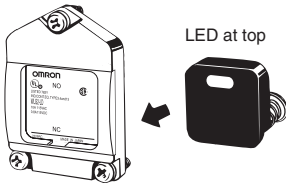

Light-ON when Not Operating

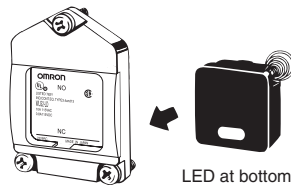

Indicator

The indicator is either a neon lamp or an LED. Models with LED indicators have a built-in rectifier stack, so it is not necessary to change the polarity.

Contact Spring

The built-in switch's terminal screws are used to connect the indicator terminal. Since the connection spring (coil spring) is used for this connection, it will not be necessary to connect the indicator terminal. When a ground terminal is provided however, a lead wire must be used.

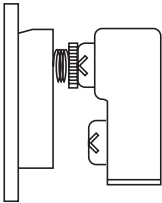

Operation

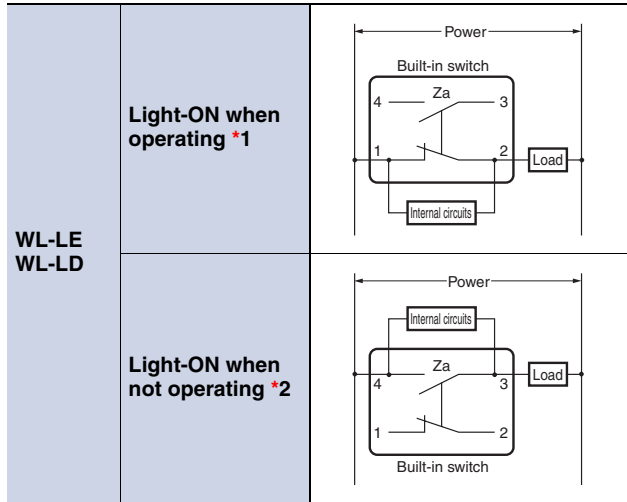

Internal Circuits

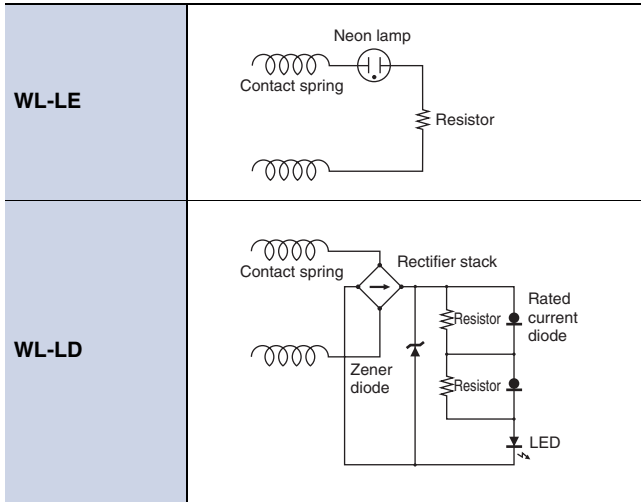

Note: 1. The indicator cover cannot be replaced on the molded terminals. In all cases the indicator does not light when the load is ON.
 2. Leakage current from indicator circuit may cause load's malfunction. Please check the load's OFF current before use the indicator-equipped switch.
 *1. Light-ON when operating means that the lamp lights when the Limit Switch contacts (NC) release, or when the actuator rotates or is pushed down.
 *2. Light-ON when not operating means the lamp remains lit when the actuator is free, or when the Limit Switch contacts (NO) close when the actuator rotates or is pushed down.

Environment-resistant Switches

Mold Specifications for Hermetic Seal Switches

■ : Molded parts

WL□-139

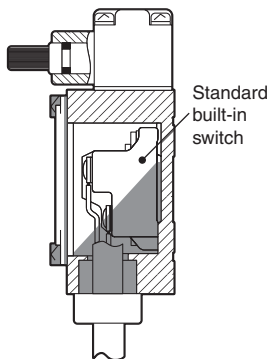

WL□-140

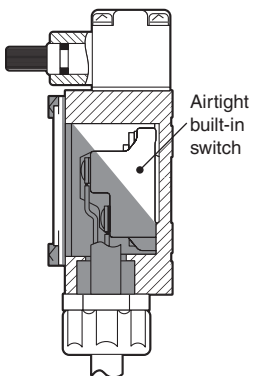

WL□-141

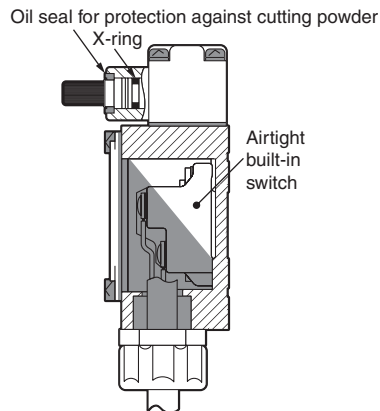

WL□-145

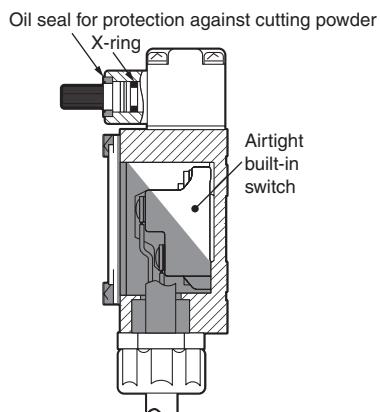

WL□-RP40

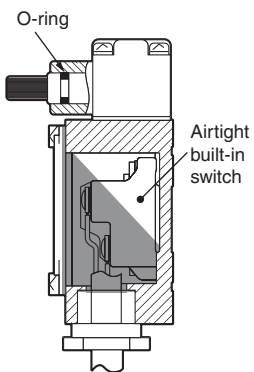

WL□-RP60

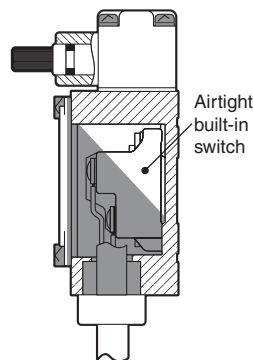

* Florine rubber is used for all rubber parts.

Model	Cable specifications
WL□-139	Standard 5-m VCT (vinyl cabtire cable) cable attached. Finished diameter: 11.5 mm, 4-conductor.
WL□-140 WL□-141 WL□-145 WL□RP40 WL□RP60	Standard 5-m VCT cable, with high flexibility and good anti-oil properties attached. Finished diameter: 11.5 mm, 4-conductor.

Spatter-prevention Switches: WLCA2-LEAS

Actuator

Roller, Roller Axis
Using stainless steel prevents spatter from adhering.

Operating Lever
Melamine sinter-painted, it is easy to peel off the spatter.

Double Nut
SUS is used for double nut.

Lamp Cover

· Heat-resistant resin is used for the lamp cover.
· By using spherical surface for the display part, it disperses the direction of spatter.

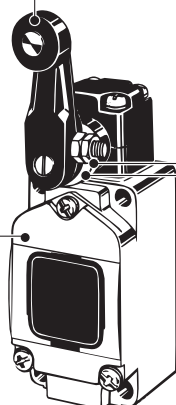

Screws

SUS is used, preventing spatter from adhering.

Head Cap

Using fluororesin prevents spatter from adhering.

* Spatter means the zinc powder produced when welding.
Adhering spatter to the Limit Switch may cause malfunction of lever or lamp cover.

The lack of gap prevents spatter powder from clogging.

Long-life Switches: WLMGCA2-LD

Release Plunger

Hardening method changed for greater abrasion resistance.

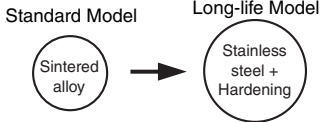

Head

The Head can be mounted in any of the four directions by removing the screws at the four corners of the Head.

Shaft Section Seal

By fitting a double seal consisting of an oil seal and an X-ring to the rotary shaft, even greater sealing properties are achieved.

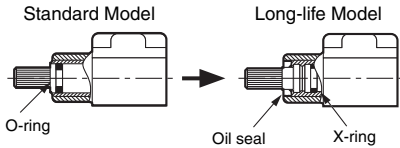

Smoother Movement

A grease holder is provided on the shaft to prevent the grease from running out.

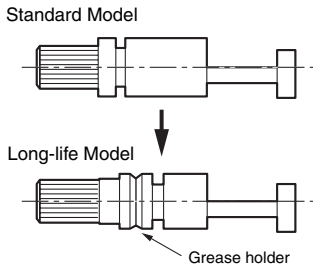

Smooth movement is achieved using olefin grease. (Standard models use molybdenum disulfide grease.)

Bearing

The bearing smooths the plunger movement.

Built-in Switch

Built-in switch with SPST-NO+NC contact form.

Set Position Marker Plate

The set position is easy to view. The stroke is indicated in fluorescent color that is visible from the slit in the rubber cap.

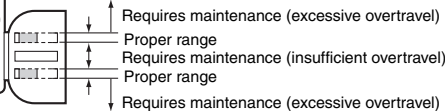
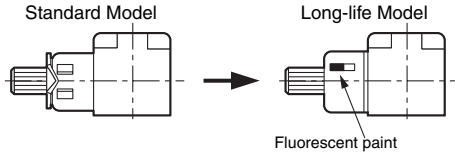

Actuator

Roller: The roller is made of self-lubricating stainless sintered and boasts high resistance to wear.

Lever: The lever forged of anti-corrosive aluminium alloy features high corrosion resistance and outstanding ruggedness. With roller lever models, the actuator position can be set anywhere within 360°. (The lever cannot be mounted in the opposite direction.)

Operational Plunger *

Cover Seal: By using a packing seal as the cover seal, an optimum squeeze can be obtained and high sealing properties are assured as well.

Terminal Screws: Four, M4 screws

Cover

Separator

The separator has outstanding insulation properties and prevents the generation of any gases which may corrode the internal parts.

Cover Mounting Screw

Phillips screws are used to ensure ease of use.

Head Mounting Screws

Conduit Opening

In addition to level screws which use G1/2 tube, direct-wired and pre-wired connectors have been added to the Series.

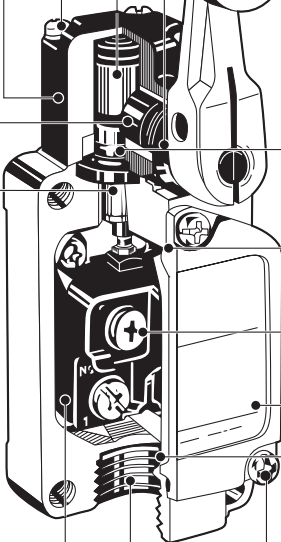

* By changing the direction of the operational plunger, any one of the three operational directions (both sides, left, or right) can be selected.

Contact Forms

Screw Terminal Switches

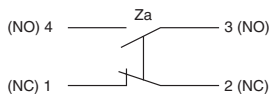

Screw Terminal Switches

Indicator-equipped (Light-ON when Not Operating) Switches *1

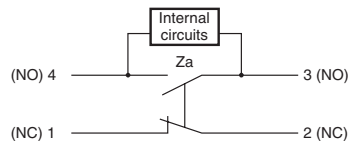

Direct-wired Connector Switches

Indicator-equipped (Light-ON when Not Operating) Switches *1

AC

DC

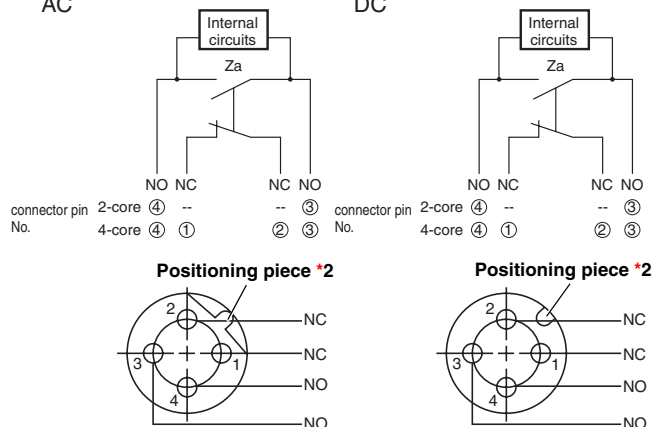

Pre-wired Connector Switches

Indicator-equipped (Light-ON when Not Operating) Switches *1

DC (2-core)

DC (3-core, 4-core)

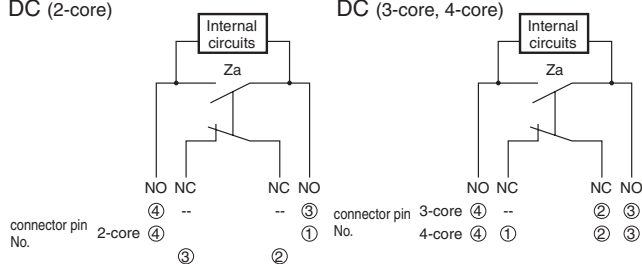

Note: Leakage current from indicator circuit may cause load's malfunction. Please check the load's OFF current before use the indicator-equipped switch.
 *1. Light-ON when not operating means the indicator is lit when the actuator is free and is not light when the Switch contacts (NO) close when the actuator rotates or is pushed down.
 *2. The position of the positioning piece is not always the same. If using an L-shaped connector causes problems in application, use a straight connector.

Dimensions and Operating Characteristics

(Unit: mm)

General-purpose Models

Standard Models

Basic

Rotating Lever For all models WL□ indicates a standard-load model and WL01□ indicates a microload model.

Roller lever R38

WLCA2
WL01CA2

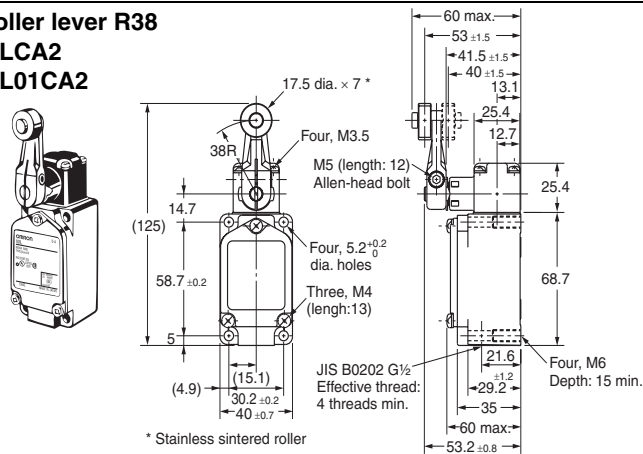

* Stainless sintered roller

Roller lever R50

WLCA2-7
WL01CA2-7

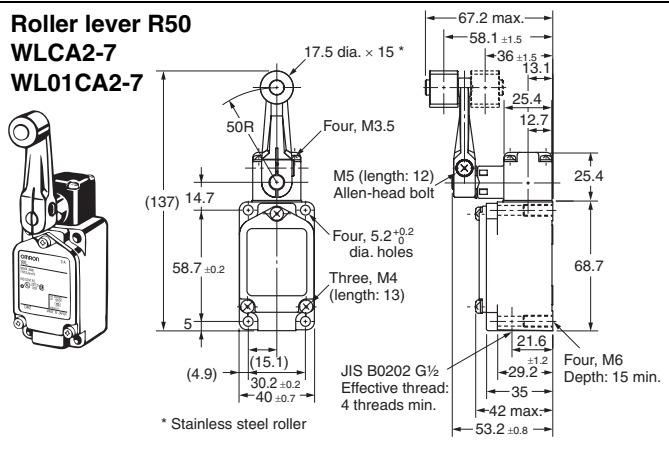

* Stainless steel roller

Roller lever R63

WLCA2-8
WL01CA2-8

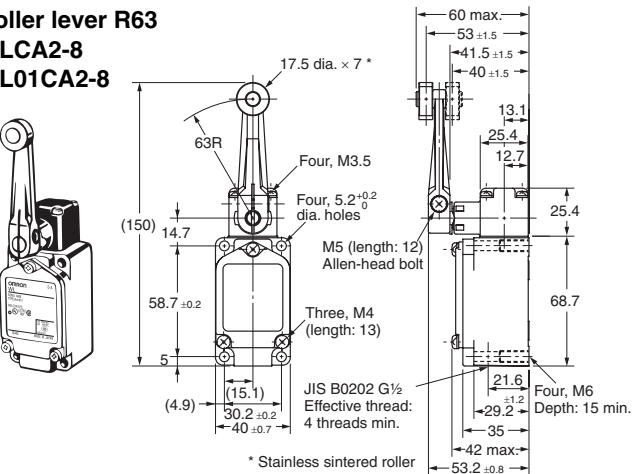

* Stainless sintered roller

Adjustable Roller Lever

WLCA12
WL01CA12

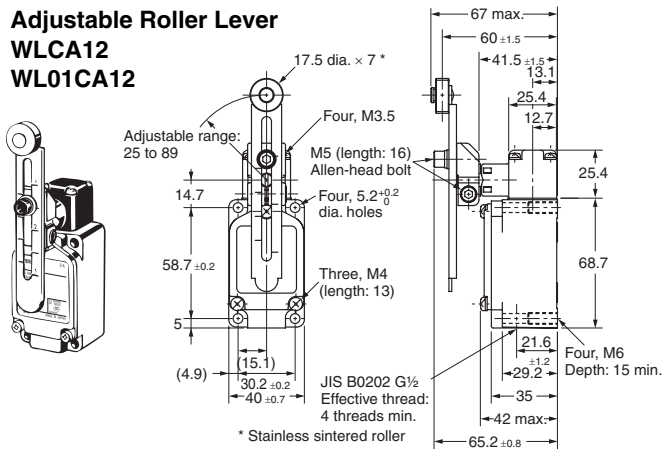

* Stainless sintered roller

Adjustable Rod Lever (25 to 140 mm)

WLCL
WL01CL

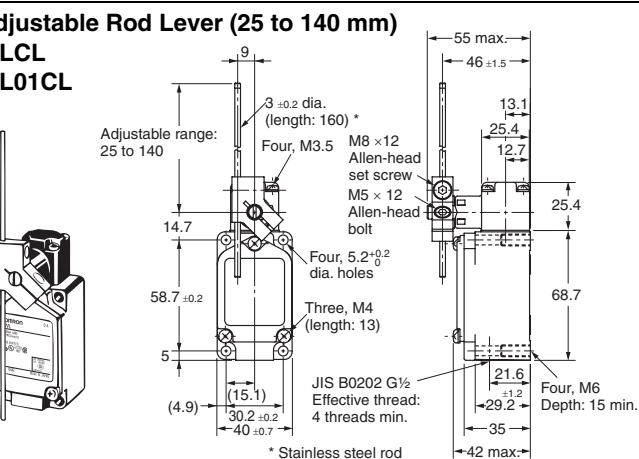

* Stainless steel rod

Fork Lever Lock

WLCA32-41 to 44
WL01CA32-41 to 44

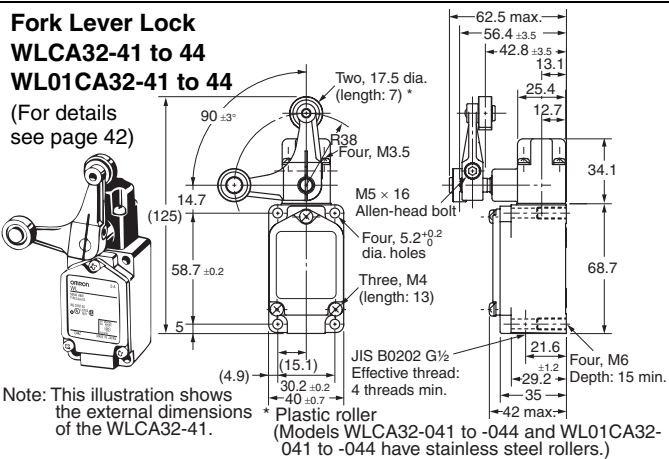

Note: This illustration shows the external dimensions of the WLCA32-41.
* Plastic roller (Models WLCA32-041 to -044 and WL01CA32-041 to -044 have stainless steel rollers.)

Note: Unless otherwise indicated, a tolerance of ±0.4 mm applies to all dimensions.

Operating characteristics	Model	WLCA2 WL01CA2	WLCA2-7 WL01CA2-7	WLCA2-8 WL01CA2-8	WLCA12 *1 WL01CA12 *1	WLCL *2 WL01CL *2
Operating force	OF max.	13.34 N	10.2 N	8.04 N	13.34 N	1.39 N
Release force	RF min.	2.23 N	1.67 N	1.34 N	2.23 N	0.27 N
Pretravel	PT	15° ±5°	15° ±5°	15° ±5°	15° ±5°	15° ±5°
Overtravel	OT min.	30°	30°	30°	30°	30°
Movement Differential	MD max.	12°	12°	12°	12°	12°

*1. The operating characteristics for WLCA12 and WL01CA12 are measured at the lever length of 38 mm.

*2. The operating characteristics for WLCL and WL01CL are measured at the rod length of 140 mm.

Operating characteristics	Model	WLCA32-41 to 44 *1 WL01CA32-41 to 44 *1
Force necessary to reverse the direction of the lever: Max.		11.77 N
Movement until the lever reverses		50° ±5°
Movement until switch operation: Min.		55°
Movement after switch operation: Max.		35°

OF and RF for WLCA12, with a lever length of 89 mm.

WLCA12, WL01CA12	
OF	5.68 N
RF	0.95 N

Basic

Plunger For all models WL□ indicates a standard-load model and WL01□ indicates a microload model.

Top Plunger

**WLD
WL01D**

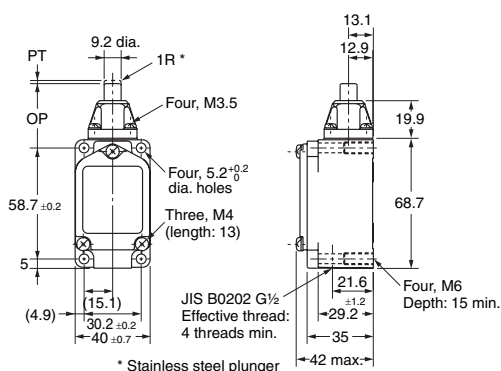

* Stainless steel plunger

Horizontal Plunger

**WLS
WL01SD**

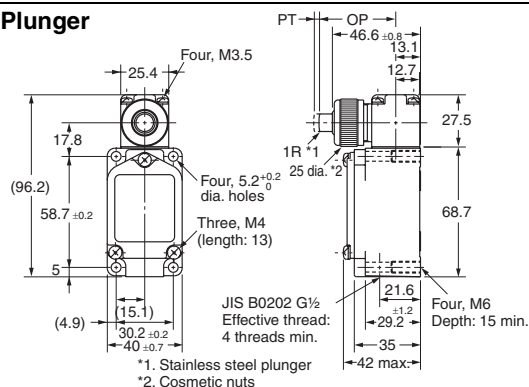

Top-roller Plunger

**WLD2
WL01D2**

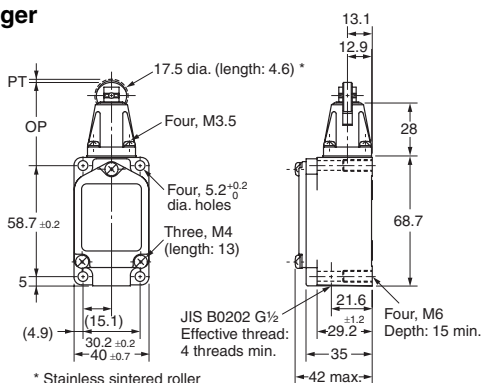

* Stainless sintered roller

Horizontal-roller Plunger

**WLS2
WL01SD2**

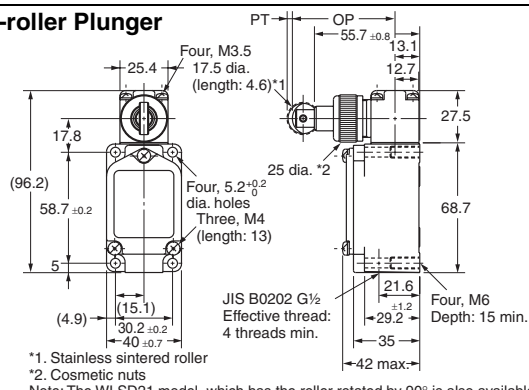

Note: The WLS21 model, which has the roller rotated by 90° is also available.

Top-ball Plunger

**WLD3
WL01D3**

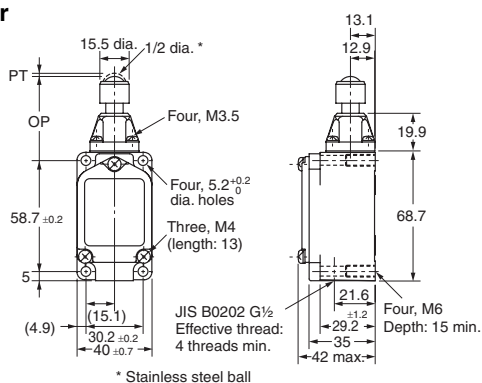

* Stainless steel ball

Horizontal-ball Plunger

**WLS3
WL01SD3**

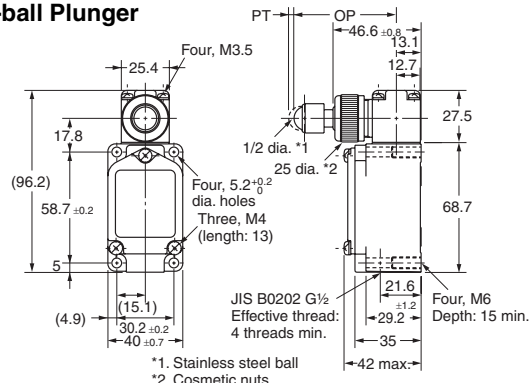

Sealed Top-roller Plunger

**WLD28
WL01D28**

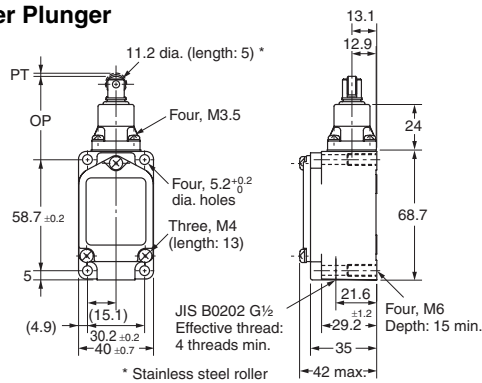

* Stainless steel roller

Note: Unless otherwise indicated, a tolerance of ±0.4 mm applies to all dimensions.

Operating characteristics	Model	WLD WL01D	WLD2 WL01D2	WLD3 WL01D3	WLD28 WL01D28	WLS2 WL01SD2	WLS3 WL01SD3	WLS WL01SD
Operating force	OF max.	26.67 N	26.67 N	26.67 N	16.67 N	40.03 N	40.03 N	40.03 N
Release force	RF min.	8.92 N	8.92 N	8.92 N	4.41 N	8.89 N	8.89 N	8.89 N
Pretravel	PT max.	1.7 mm	1.7 mm	1.7 mm	1.7 mm	2.8 mm	2.8 mm	2.8 mm
Overtravel	OT min.	6.4 mm	5.6 mm	4 mm	5.6 mm	5.6 mm	4 mm	6.4 mm
Movement Differential	MD max.	1 mm	1 mm	1 mm	1 mm	1 mm	1 mm	1 mm
Operating Position	OP	34 ±0.8 mm	44 ±0.8 mm	44.5 ±0.8 mm	44 ±0.8 mm	54.2 ±0.8 mm	54.1 ±0.8 mm	40.6 ±0.8 mm
Total travel Position	TTP max.	29.5 mm	39.5 mm	41 mm	39.5 mm	—	—	—

Basic

Flexible Rod For all models WL□ indicates a standard-load model and WL01□ indicates a microload model.

Coil Spring
WLNJ
WL01NJ

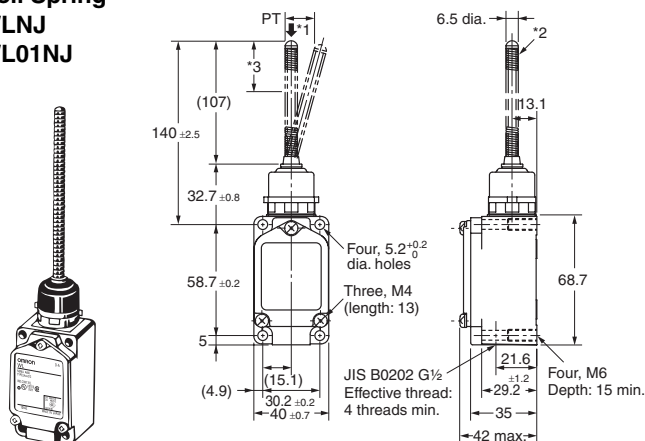

- *1. The coil spring may be operated from any direction except the axial direction (↓).
- *2. Stainless steel coil spring
- *3. Optimum operating range of the coil spring is within 1/3 of the entire length from the top end.

Coil Spring (Multi-wire)
WLNJ-30
WL01NJ-30

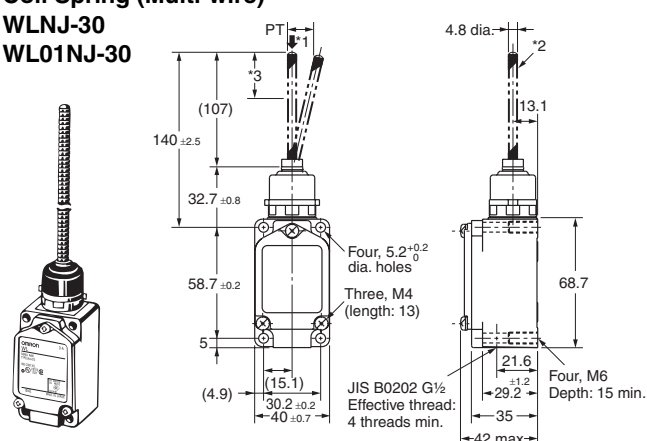

- *1. The coil spring may be operated from any direction except the axial direction (↓).
- *2. Piano wire coil
- *3. Optimum operating range of the coil spring is within 1/3 of the entire length from the top end.

Coil Spring (Resin Rod)
WLNJ-2
WL01NJ-2

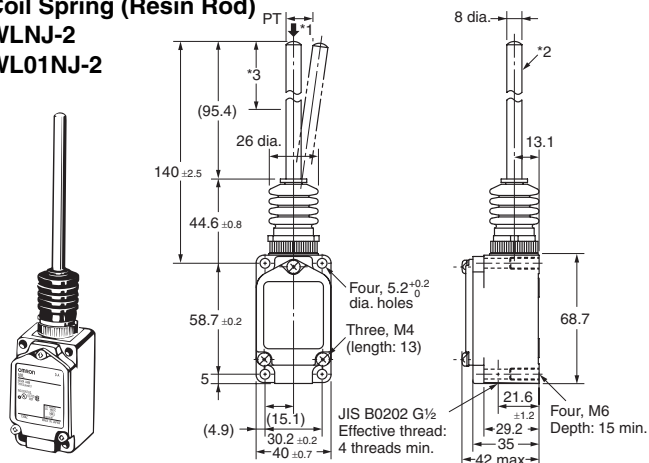

- *1. The resin rod may be operated from any direction except the axial direction (↓).
- *2. Polyamide resin rod
- *3. Optimum operating range of the resin rod is within 1/3 of the entire length from the top end.

Steel Wire
WLNJ-S2
WL01NJ-S2

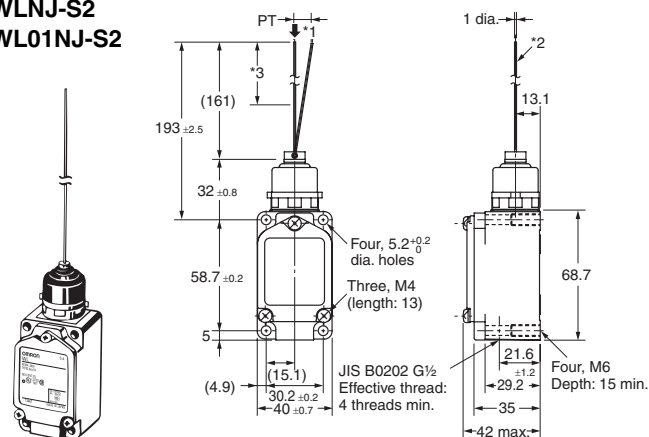

- *1. The steel wire may be operated from any direction except the axial direction (↓).
- *2. Stainless steel wire
- *3. Optimum operating range of the steel wire is within 1/3 of the entire length from the top end.

Note: Unless otherwise indicated, a tolerance of ±0.4 mm applies to all dimensions.

Model		WLNJ *	WLNJ30 *	WLNJ-2 *	WLNJ-S2 *
Operating characteristics		WL01NJ *	WL01NJ30 *	WL01NJ-2 *	WL01NJ-S2 *
Operating force	OF max.	1.47 N	1.47 N	1.47 N	0.28 N
Pretravel	PT	20 ± 10mm	20 ± 10mm	40 ± 20mm	40 ± 20mm

* These values are taken from the top end of the wire or spring.

Overtravel

General-purpose/High-sensitivity Models For all models WL□ indicates a standard-load model and WL01□ indicates a microload model.

Roller Lever R38

- WLH2
- WL01H2
- WLG2
- WL01G2

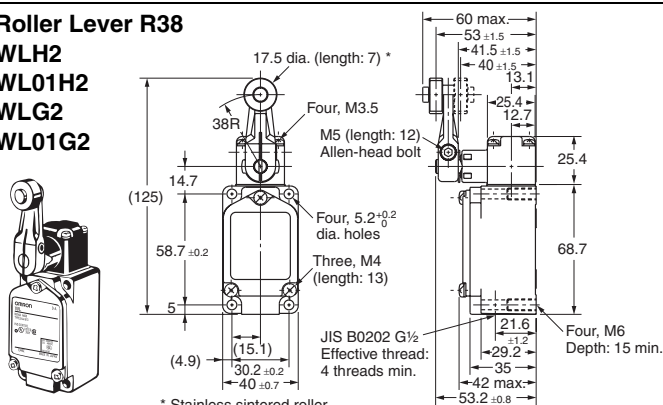

- Note: 1. WL□G2 is identical to other models except in the shape of the set position marker plate.
2. The built-in switch for WLH2 is W-10FB3.
3. The built-in switch for WLG2 is W-10FB3-8.

Adjustable Rod Lever

- WLHL
- WL01HL
- WGLL
- WL01GL

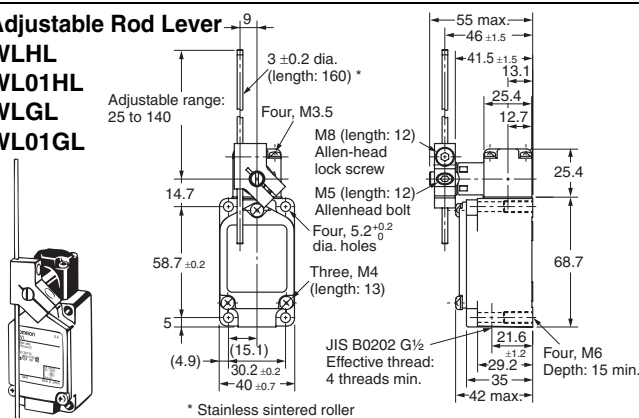

- Note: 1. WL□GL is identical to other models except in the shape of the set position marker plate.
2. The built-in switch for WLHL is W-10FB3.
3. The built-in switch for WGLL is W-10FB3-8.

Adjustable Roller Lever

- WLH12
- WL01H12
- WLG12
- WL01G12

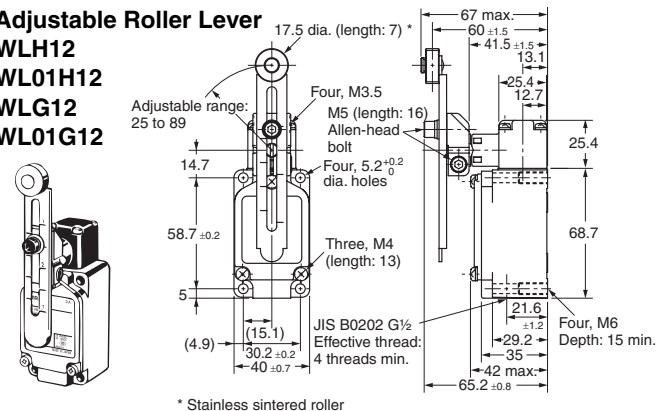

- Note: 1. WL□G12 is identical to other models except in the shape of the set position marker plate.
2. The built-in switch for WLH12 is W-10FB3.
3. The built-in switch for WLG12 is W-10FB3-8.

Adjustable Rod Lever

- WLHAL4
- WL01HAL4

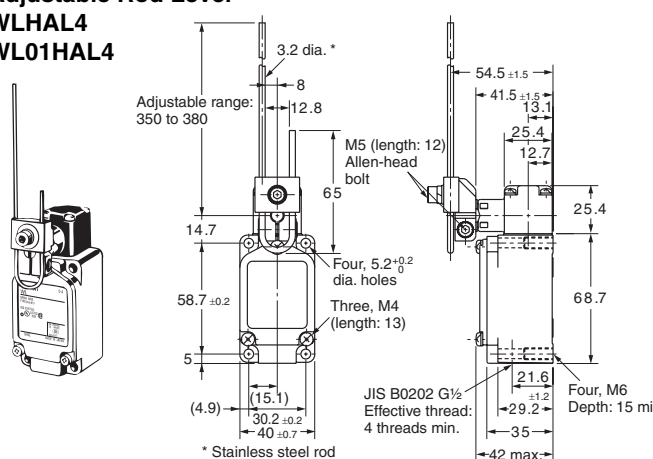

Note: Unless otherwise indicated, a tolerance of ±0.4 mm applies to all dimensions.

Rod Spring Lever

- WLHAL5
- WL01HAL5

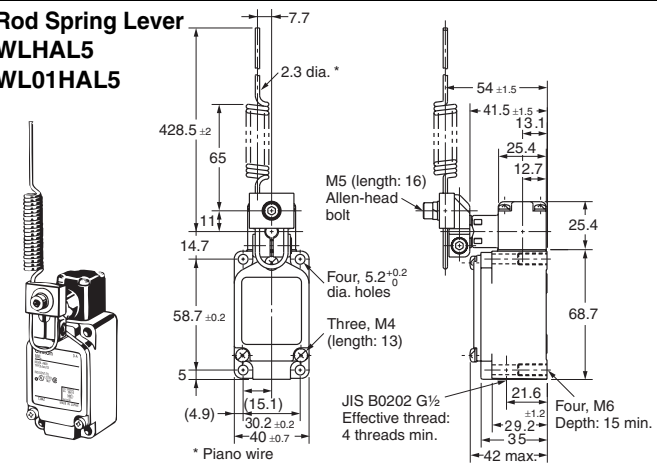

OF and RF for WLH12 and WL01H12, with a lever length of 89 mm.

	WLH12, WLA01H12	WLG12, WL01G12
OF	4.18 N	4.18 N
RF	0.42 N	0.42 N

	Model	WLH2 WL01H2	WLG2 WL01G2	WLH12 *1 WL01H12 *1	WLG12 *1 WL01G12 *1	WLHL *1 WL01HL *1	WGLL *2 WL01GL *2	WLHAL4 *3 WL01HAL4 *3	WLHAL5 WL01HAL5
Operating characteristics									
Operating force	OF max.	9.81 N	9.81 N	9.81 N	9.81 N	2.84 N	2.84 N	0.98 N	0.90 N
Release force	RF min.	0.98 N	0.98 N	0.98 N	0.98 N	0.25 N	0.25 N	0.15 N	0.09 N
Pretravel	PT	15° ±5°	10° ±2°	15° ±5°	10° ±2°	15° ±5°	10° ±2°	15° ±5°	15° ±5°
Overtravel	OT min.	55°	65°	55°	65°	55°	65°	55°	55°
Movement Differential	MD max.	12°	7°	12°	7°	12°	7°	12°	12°

Note: With WLHAL4, WL01HAL4, WLHAL5, and WL01HAL5, the actuator's tare is large, so depending on the installation direction, they may not be properly reset. Always install so that the actuator is facing downwards.

*1. The operating characteristics of WLH12, WL01H12, WLG12, and WL01G12 are measured at the lever length of 38 mm.

*2. The operating characteristics of WLHL, WL01HL, WGLL, and WL01GL are measured at the rod length of 140 mm.

*3. The operating characteristics of WLHAL4, and WL01HAL4 are measured at the rod length of 380 mm.

Overtravel

Side-installation Models ... For all models WL□ indicates a standard-load model and WL01□ indicates a microload model.

Roller Lever
WLCA2-2N
WL01CA2-2N

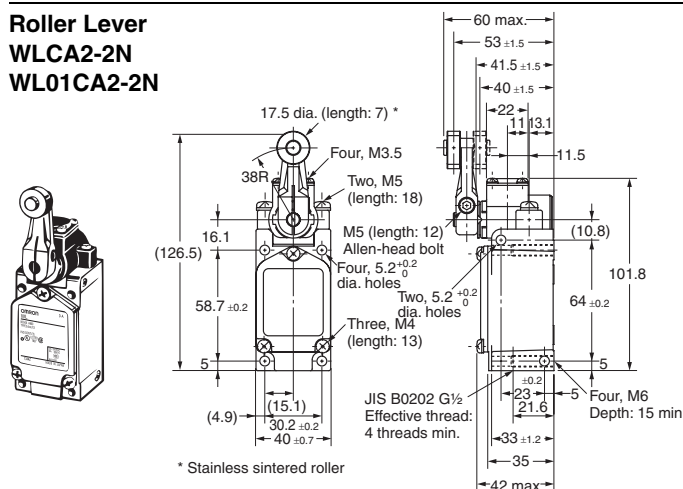

Roller Lever
WLCA2-2
WL01CA2-2

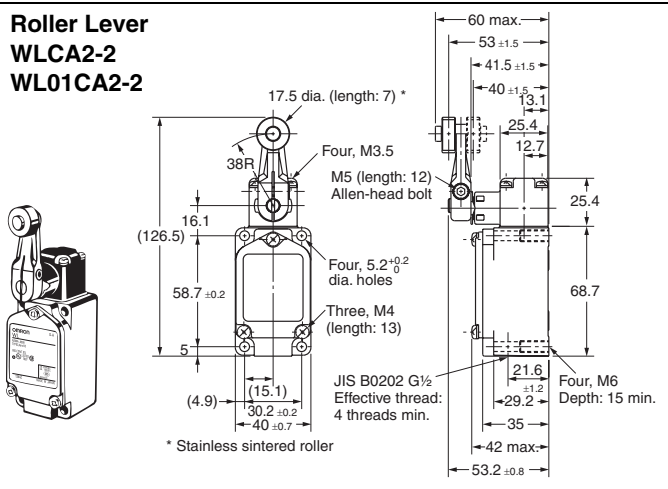

Adjustable Roller Lever
WLCA12-2N
WL01CA12-2N

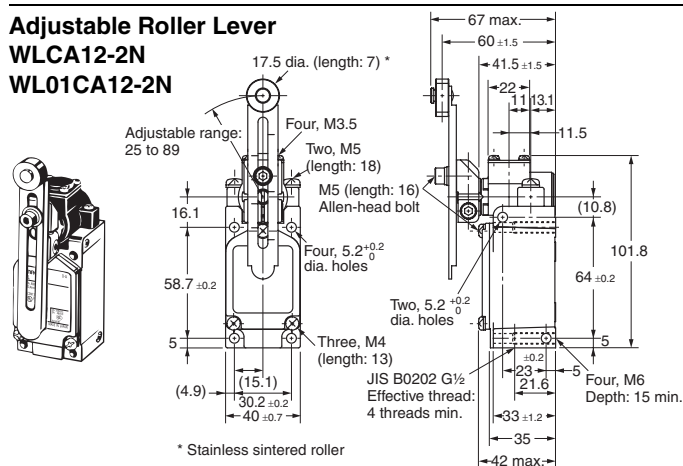

Adjustable Roller Lever
WLCA12-2
WL01CA12-2

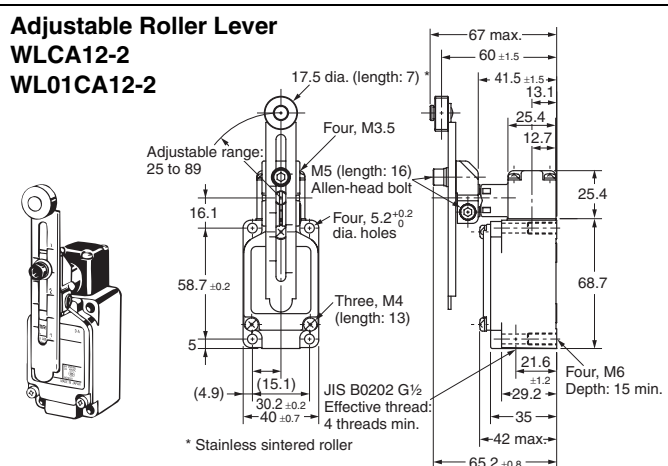

Adjustable Rod Lever
WLCL-2N
WL01CL-2N

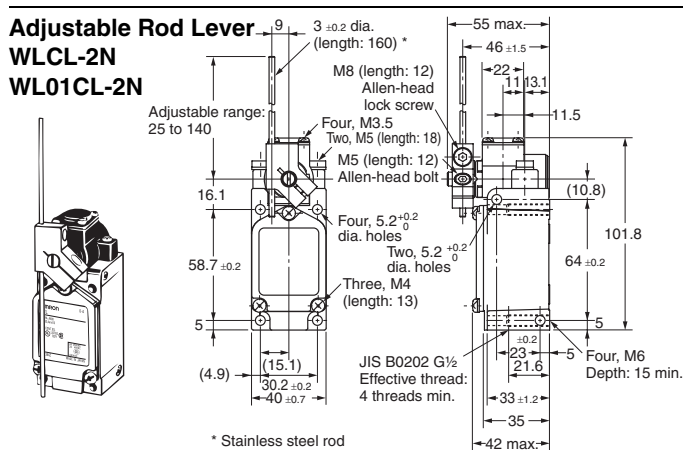

Adjustable Rod Lever
WLCL-2
WL01CL-2

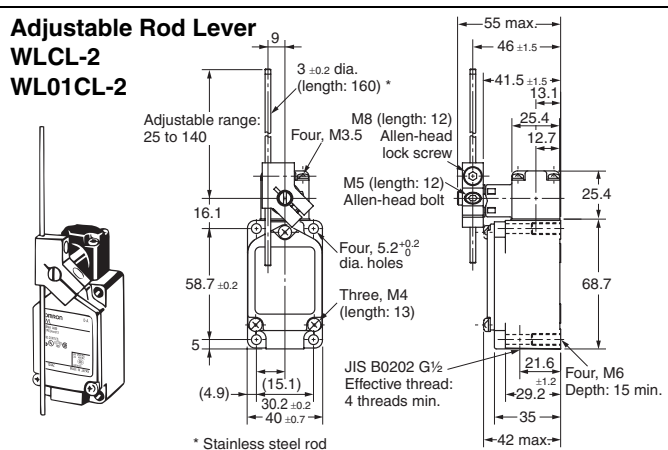

Note: Unless otherwise indicated, a tolerance of ±0.4 mm applies to all dimensions.

Model		WLCA2-2N	WLCA12-2N*1	WLCL-2N*2	WL01CA2-2	WLCA12-2*1	WLCL-2*2
Operating characteristics		WL01CA2-2N	WL01CA12-2N*1	WL01CL-2N*2	WL01CA2-2	WL01CA12-2*1	WL01CL-2*2
Operating force	OF max.	9.61 N	9.61 N	2.84 N	8.83 N	8.83 N	2.55 N
Release force	RF min.	1.18 N	1.18 N	0.25 N	0.49 N	0.49 N	0.1 N
Pretravel	PT	20° max.	20° max.	20° max.	25° ±5°	25° ±5°	25° ±5°
Overtravel	OT min.	70°	70°	70°	60°	60°	60°
Movement Differential	MD max.	10°	10°	10°	16°	16°	16°

*1. The operating characteristics of WLCA12-2N and WL01CA12-2N are measured at the lever length of 38 mm.
 *2. The operating characteristics of WLCL-2N and WL01CL-2N are measured at the rod length of 140 mm.

OF and RF for WLCA12-2N and WL01CA12-2N, with a lever length of 89 mm.

	WLCA12-2N, WL01CA12-2N
OF	4.10 N
RF	0.50 N

High-precision Models

WL□ are Standard Models and WL01□ are Microload Models.

**Roller Lever
WLGCA2
WL01GCA2**

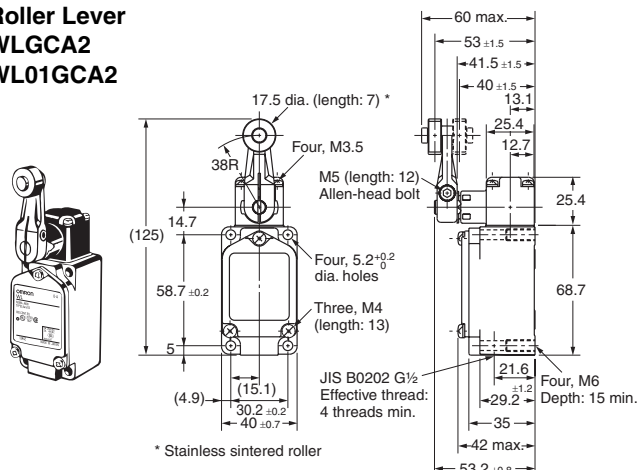

Model		WLGCA2 WL01GCA2
Operating characteristics		
Operating force	OF max.	13.34 N
Release force	RF min.	1.47 N
Pretravel	PT	5° ^{+2°} _{0°}
Overtravel	OT min.	40°
Movement Differential	MD max.	3°

Note: Unless otherwise indicated, a tolerance of ±0.4 mm applies to all dimensions.

Sensor I/O Connector Switches

Direct-wired Connector/Pre-wired Connector Models

Refer to page 27 and *Connecting Cables* in the *Limit Switch Connectors*.

Roller Lever PlungersWL□ are Standard Models and WL01□ are Microload Models.

Standard Models (WLCA2), High-precision Models (WLGCA2),

Overtravel General-purpose Models (WLH2), Overtravel High-sensitivity Models (WLG2)

Connector Models

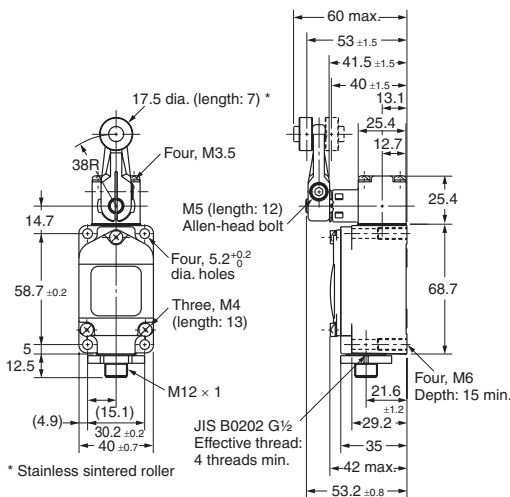

Pre-wired Connector Models

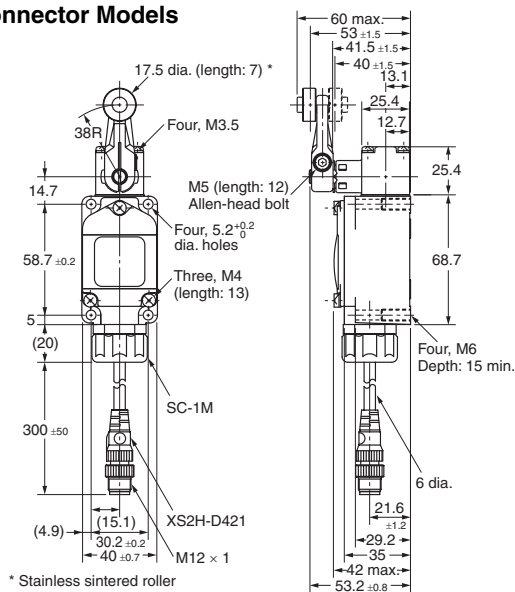

Note: 1. Only the dimension of the set position marker plate is different for WLG2 Models.
 2. Unless otherwise indicated, a tolerance of ±0.4 mm applies to all dimensions.
 3. The models with operation indicators are shown in the above diagrams.

Actuator		Standard roller lever actuator	High-precision roller lever actuator	Overdrive general-purpose actuator	Overdrive high-sensitivity actuator
Operating characteristics					
Operating force	OF max.	13.34 N	13.34 N	9.81 N	9.81 N
Release force	RF min.	2.23 N	1.47 N	0.98 N	0.98 N
Pretravel	PT	15° ±5°	5° ^{+2°} _{0°}	15° ±5°	10° ^{+2°} _{0°}
Overtravel	OT min.	30°	40°	55°	65°
Movement Differential	MD max.	12°	3°	12°	7°

Top-roller Plunger (WLD2)

Direct-wired Connector Models

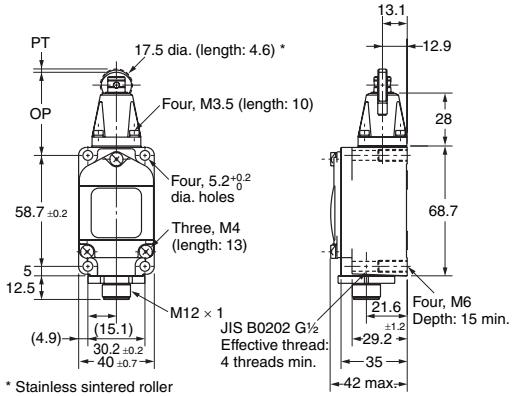

* Stainless sintered roller

Pre-wired Connector Models

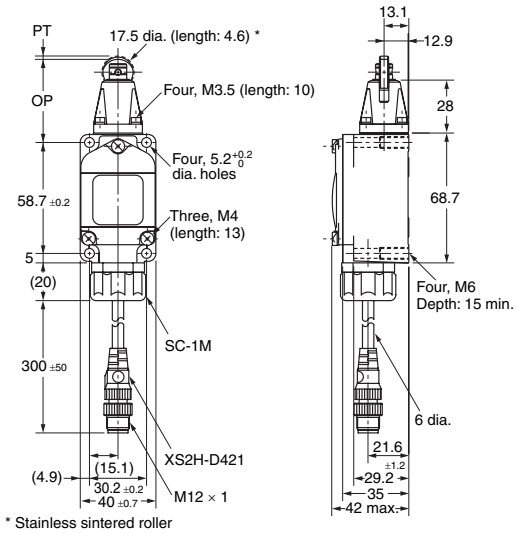

* Stainless sintered roller

Note: 1. Unless otherwise indicated, a tolerance of ±0.4 mm applies to all dimensions.
 2. The following diagrams are for a indicator-equipped models.

Actuator		Top-roller plunger
Operating force	OF max.	26.67 N
Release force	RF min.	8.92 N
Pretravel	PT max.	1.7 mm
Overtravel	OT min.	5.6 mm
Movement Differential	MD max.	1 mm
Operating Position	OP	44 ±0.8mm
Total travel Position	TTP max.	39.5 mm

Indicator-equipped Models

Roller Lever
 WLCA2-LE/LD
 WL01CA2-LE/LD

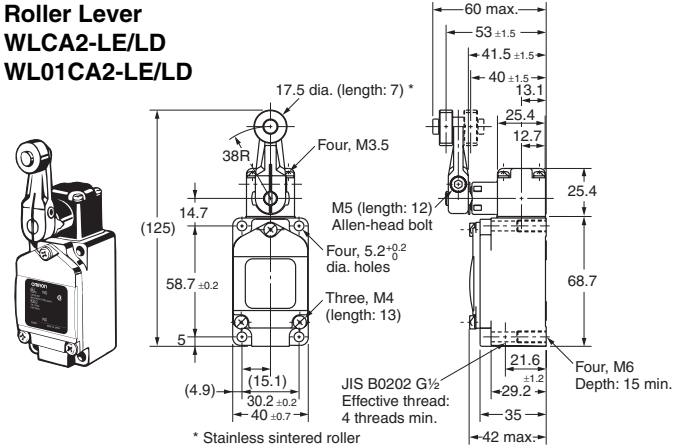

* Stainless sintered roller

Note: Unless otherwise indicated, a tolerance of ±0.4 mm applies to all dimensions.

Actuator		WLCA2-LE/LD WL01CA2-LE/LD
Operating force	OF max.	13.34 N
Release force	RF min.	2.23 N
Pretravel	PT	15° ±5°
Overtravel	OT min.	30°
Movement Differential	MD max.	12°

Long-life Models

Rotating Lever Models

Roller Lever (Screw Terminals)

WLM□-LD

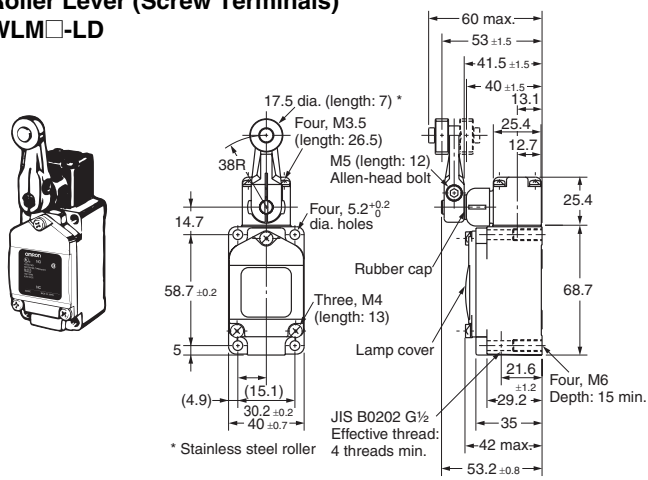

Roller Lever (Direct-wired Connectors)

WLM□-LD□

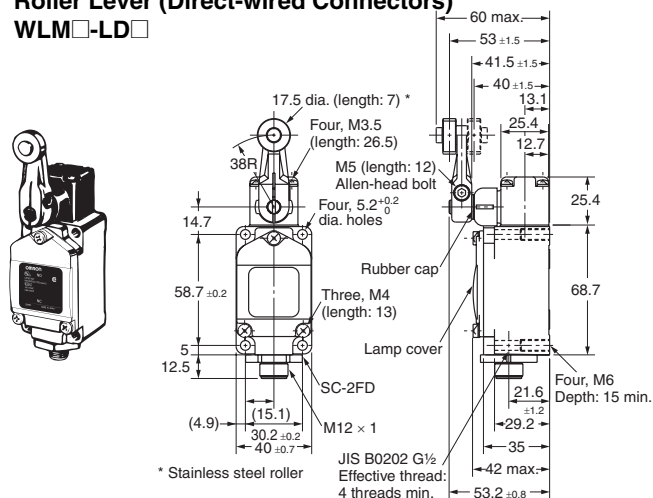

Roller Lever (Pre-wired Connectors)

WLM□-LD□

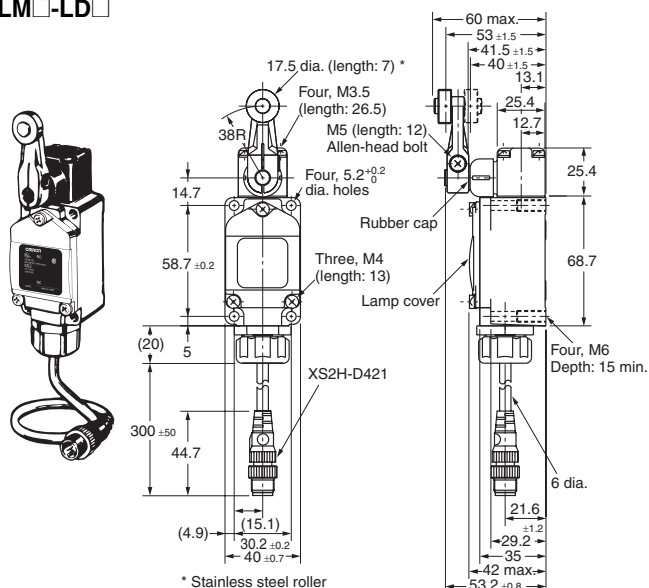

Note: Unless otherwise indicated, a tolerance of ±0.4 mm applies to all dimensions.

Model		WLMCA2-LD□ Basic models	WLMH2-LD□ General-purpose overtravel models	WLMG2-LD□ High-sensitivity overtravel models	WLMGCA2-LD□ High-precision models
Operating characteristics					
Operating force	OF max.	9.81 N	9.81 N	9.81 N	13.34 N
Release force	RF min.	0.98 N	0.98 N	0.98 N	1.47 N
Pretravel	PT	15° ±5°	15° ±5°	10 ^{°+2°} / _{-1°}	5 ^{°+2°} / _{0°}
Overtravel	OT min.	30°	55°	65°	40°
Movement Differential	MD max.	12°	12°	7°	3°

Actuators (Levers Only)

Lever: Only rotating lever models are illustrated.

<p>WL-1A100 Standard Lever</p>	<p>WL-1A115 Resin Roller</p>	<p>WL-1A400 Bearing Roller</p>	<p>WL-1A118 Nylon Roller: Roller Width: 30 mm</p>
<p>WL-1A105 Double Nuts</p>	<p>WL-1A103S Spatter Prevention</p>	<p>WL-1A200 Lever Length: 50 Roller Width: 15</p>	<p>WL-1A300 Lever Length: 63</p>
<p>WL-2A100</p>	<p>WL-2A111 Resin Roller</p>	<p>WL-2A107 Double Nuts</p>	<p>WL-2A108 Resin Roller</p>
<p>WL-2A122</p>	<p>WL-2A106</p> <p>Can be installed on the rear side.</p>	<p>WL-2A130</p>	<p>WL-2A104</p>

Note: Unless otherwise indicated, a tolerance of ± 0.4 mm applies to all dimensions.

Lever: Only rotating lever models are illustrated.

WL-2A110

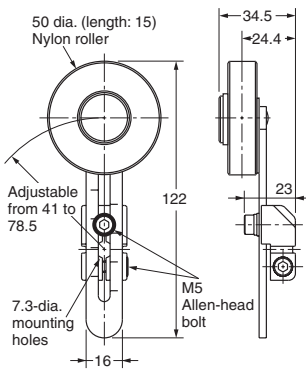

WL-2A105

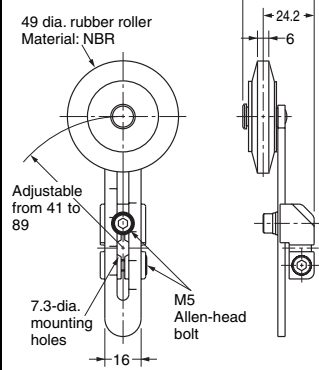

WL-1A106

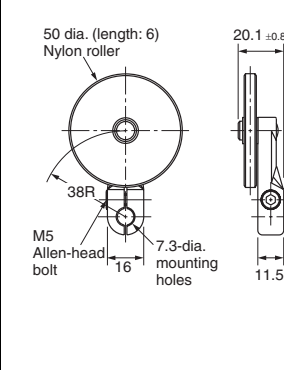

WL-1A110

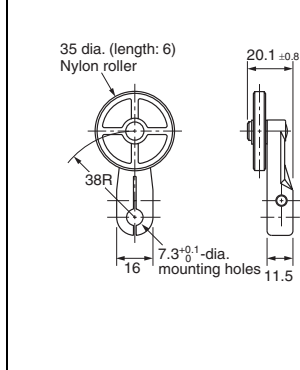

WL-4A100

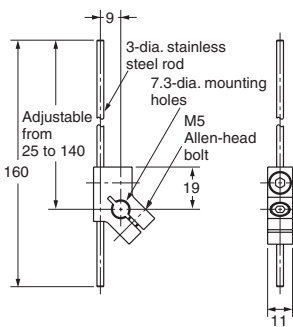

WL-4A201

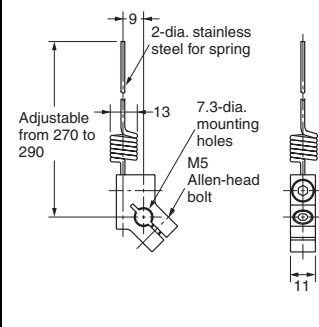

WL-3A100

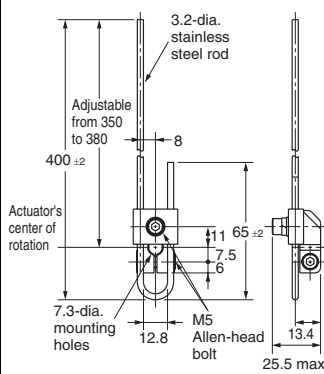

**WL-3A106
Double Nut**

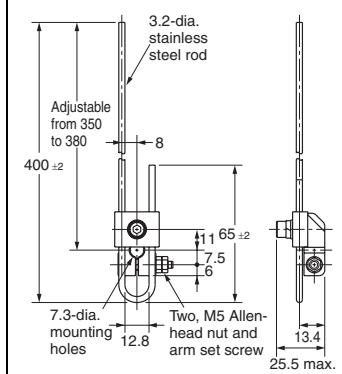

WL-3A108

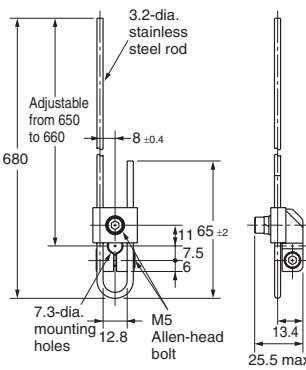

WL-3A200

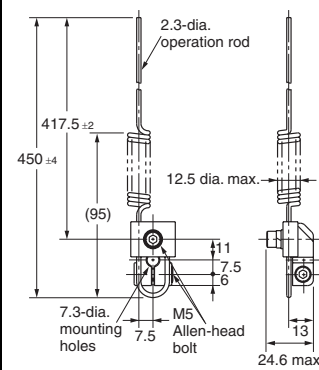

WL-3A203

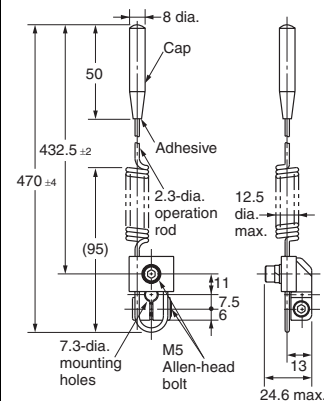

WL-4A112

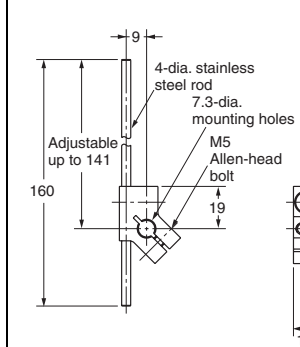

WL-2A129

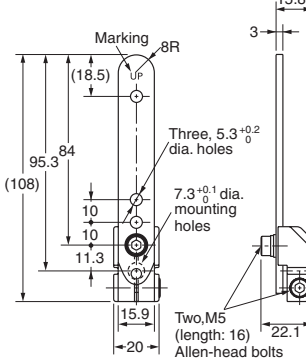

WL-5A101

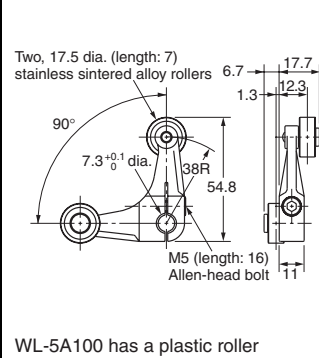

WL-5A103

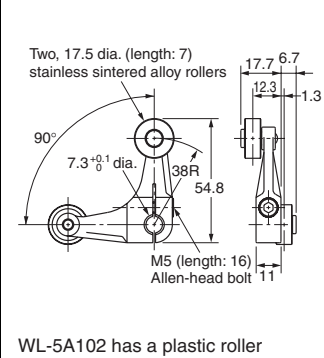

WL-5A105

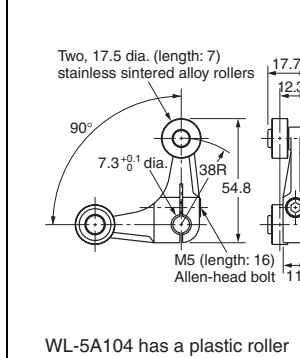

Note: 1. Unless otherwise indicated, a tolerance of ±0.4 mm applies to all dimensions.

2. When using the adjustable roller (rod) lever, make sure that the lever is facing downwards. Use caution, as telegraphing (the Switch turns ON and OFF repeatedly due to inertia) may occur.

Safety Precautions

Refer to *Safety Precautions for All Limit Switches*.

Precautions for Safe Use

- When a rod or wired-type actuator is used, do not touch the top end of the actuator. Doing so may result in injury.
(Applicable models)
WLHAL5 and WL01HAL5 Rod Spring Levers and WLNJ-S2 and WL01NJ-S2 Steel-wire Actuators.
- A short-circuit may cause damage to the Switch, so insert a circuit breaker fuse, of 1.5 to 2 times the rated current, in series with the Switch.
- In order to meet EN approval ratings, use a 10-A fuse that corresponds to IEC60269, either a gI or gG for general-purpose types and spatter-prevention models only.

Precautions for Correct Use

- When wiring terminal screws, use M4 round crimp terminals and tighten screws to the recommended torque. Wiring with bare wires, or incorrect crimp terminals, or not tightening screws to the recommended torque can lead to short-circuits, leakage current, and fire.
- When performing internal wiring there is a chance of short-circuit, leakage current, or fire, so be sure to protect the inside of the Switch from splashes of oil or water, corrosive gases, and cutting powder.
- Using an inappropriate connector or assembling Switches incorrectly (assembly, tightening torque) can result in malfunction, leakage current, or fire, so be sure to read the instruction manual thoroughly beforehand.
- Even when the connector is assembled and set correctly, the end of the cable and the inside of the Switch may come in contact. This can lead to malfunction, leakage current, or fire, so be sure to protect the end of the cable from splashes of oil or water and corrosive gases.

Operating Environment

- Seal material may deteriorate if a Switch is used outdoor or where subject to special cutting oils, solvents, or chemicals. Always appraise performance under actual application conditions and set suitable maintenance and replacement periods.
- Install Switches where they will not be directly subject to cutting chips, dust, or dirt. The Actuator and Switch must also be protected from the accumulation of cutting chips or sludge.

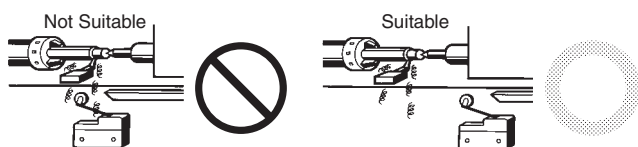

- Constantly subjecting a Switch to vibration or shock can result in wear, which can lead to contact interference with contacts, operation failure, reduced durability, and other problems. Excessive vibration or shock can lead to false contact operation or damage. Install Switches in locations not subject to shock and vibration and in orientations that will not produce resonance.
- The Switches have physical contacts. Using them in environments containing silicon gas will result in the formation of silicon oxide (SiO₂) due to arc energy. If silicon oxide accumulates on the contacts, contact interference can occur. If silicon oil, silicon filling agents, silicon cables, or other silicon products are present near the Switch, suppress arcing with contact protective circuits (surge killers) or remove the source of silicon gas.

Using Switches for Micro Loads

Contact faults may occur if a Switch for a general-load is used to switch a micro load circuit. Use switches in the ranges shown in the diagram below. However, even when using micro load models within the operating range shown here, if inrush current occurs when the contact is opened or closed, it may increase contact wear and so decrease durability. Therefore, insert a contact protection circuit where necessary. The minimum applicable load is the N-level reference value. This value indicates the malfunction reference level for the reliability level of 60% (λ_{60}). The equation, $\lambda_{60} = 0.5 \times 10^{-6}$ /operations indicates that the estimated malfunction rate is less than 1/2,000,000 operations with a reliability level of 60%.

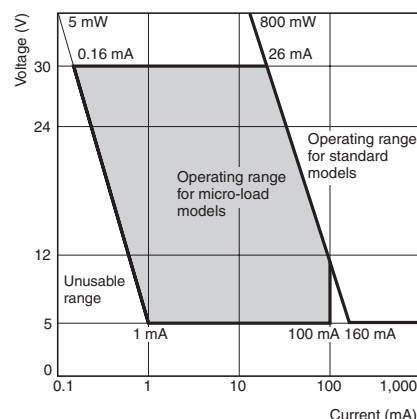

Built-in Switch

Do not remove or replace the built-in switch. If the position of the built-in switch moves, it can cause reduced performance, and if the insulation sheet moves (separator), the insulation may become ineffective.

Tightening Torque

- If screws are too loose they can lead to an early malfunction of the Switch, so ensure that all screws are tightened using the correct torque.
- In particular, when changing the direction of the Head, make sure that all screws are tightened again to the correct torque. Do not allow foreign objects to fall into the Switch.

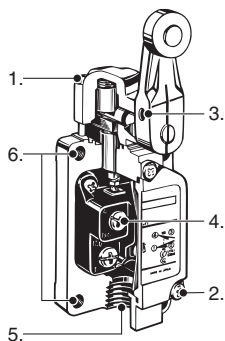

No.	Type	Appropriate tightening torque
1.	Head mounting screw	0.78 to 0.88 N·m
2.	Cover mounting screw	1.18 to 1.37 N·m
3.	Allen-head bolt (for securing the lever)	4.90 to 5.88 N·m
4.	Terminal screw	0.59 to 0.78 N·m
5.	Connector	1.77 to 2.16 N·m

Installing the Switch

To install the Switch, make a mounting panel, as shown in the following diagram, and tighten screws using the correct torque.

Mounting

WL	Mounting locations
<p>Front Mountig/ Rear Mountig</p> <p>Front Mountig : Four, $5.2^{+0.2}_0$ dia. holes or M5 tapped holes Rear Mountig : Four, $6.2^{+0.2}_0$ dia. holes</p>	
<p>In case of side mounting for overtravel, 90° WL□-□□2N</p> <p>Side Mountig</p> <p>Two, $5.2^{+0.2}_0$ dia. holes</p>	

Connectors

Either the easy-to-use Allen-head nut or the SC Connector can be used as connectors. To ensure high-sealing properties, use the SC Connector. Refer to *Limit Switch Connectors* for details on SC Connectors.

Wiring

- Use 1.25-mm² lead wires and M4-insulation covered crimp terminals for wiring.

Crimp Terminal External Dimensions

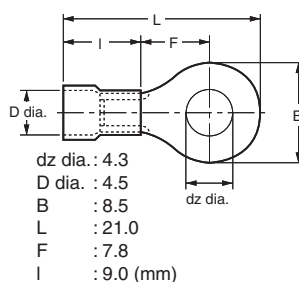

Wiring Method Switch Box Section

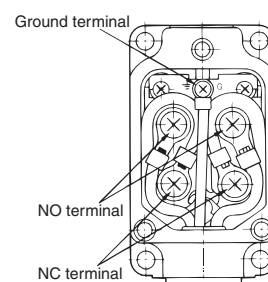

- The ground terminal is only installed on models with ground terminals.

Rotating Lever Set Position (General-purpose or Spatter-prevention Switches Only)

All rotating lever models, except the fork lever lock models, have a set position marker plate. (See page 23.) After operation, set the indicator needle on the marker plate so that is in the convex section of the bearing.

Operation Set Position (Long-life Switches Only)

For all Long-life Switching, there is a set position marker slit on the rubber cap of the head. After operation, set the slit on the rubber cap so that the fluorescent color on the shaft section can be seen.

Terminal Plate

By using a short circuit plate, as shown in the following diagram, the Switch can be fabricated into a single-polarity double-break switch. When ordering, specify WL Terminal Plate (product code: WL-9662F).

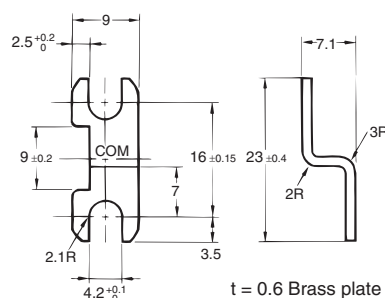

Indicator

Indicator-equipped switch has contacts and indicator in parallel. When contacts are open, leakage current flows through the indicator circuit and may cause load's malfunction. Please check the load's OFF current before use the indicator-equipped switch.

Using the Switches

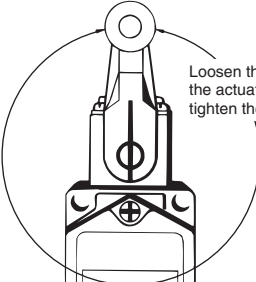
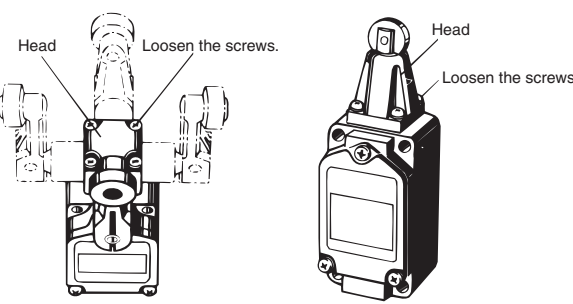
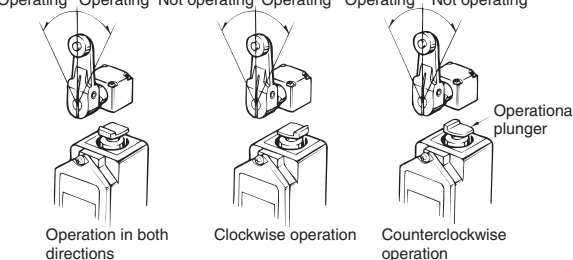
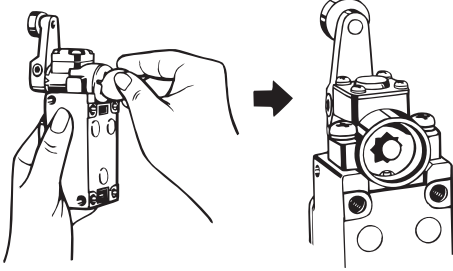
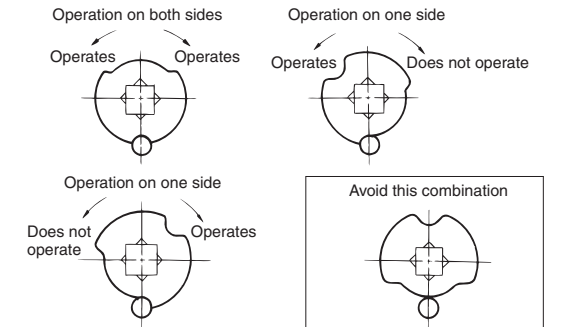
Item	Applicable models and Actuators	Details
<p>Changing the Installation Position of the Actuator</p> <p>By loosening the Allen-head bolt on the actuator lever, the position of the actuator can be set anywhere within the 360°. With Indicator-equipped Switches, the actuator lever comes in contact with the top of the indicator cover, so use caution when rotating and setting the lever. When the lever only moves forwards and backwards, it will not contact the lamp cover (except for long-life models).</p>	<p>Roller Levers: WLCA2, WL01CA2, WLCA2-2, WL01CA2-2, WLH2, WL01H2, WLG2, WL01G2, WLMCA2□, WLMH2□, WLMG2□, WLMGCA2□ Adjustable Roller Levers: WLCA12, WL01CA12, WLCA12-2, WL01CA12-2, WLH12, WL01H12, WLG12, WL01G12, Adjustable Rod Levers: WLCL, WL01CL, WLCL-2, WL01CL-2, WLHL, WL01HL, WLGL, WL01GL</p>	 <p>Loosen the M5 × 12 bolt, set the actuator's position and then tighten the bolt again.</p>
<p>Changing the Orientation of the Head</p> <p>By removing the screws in the four corners of the Head, the Head can be set in any of the four directions. Be sure to change the plunger for internal operations at the same time. (The operational plunger does not need to be changed on general-purpose and high-sensitivity overtravel models.) The roller plunger can be set in either two positions at 90°.</p> <p>WLCA2-2N and WL01CA2-2N can be set only in either the forward or backward direction.</p>	<p>Roller Levers: WLCA□, WL01CA□, WLCA□-2, WL01CA□-2, WLGCA□, WLH□, WL01H□, WLG□, WL01G□, WLMCA2□, WLMH2□, WLMG2□, WLMGCA2□ Adjustable Rod Levers: WLCL, WL01CL, WLCL-2, WL01CL-2 Horizontal Plungers: WLS□, WL01SD□ Top-roller Plungers: WLD2, WL01D2 Sealed Top-roller Plungers: WLD28, WL01D28 Does not include -RP60 Series or -141 Series.</p>	 <p>Head Loosen the screws.</p> <p>Head Loosen the screws.</p>
<p>Changing the Operating Direction</p> <p>By removing the Head on models which can operate on one-side only, and then changing the direction of the operational plunger, one of three operating directions can be selected. For overtravel 90° operation models, one of three operating directions can be selected by loosening the rubber holder using either a coin or a flat-blade screwdriver and changing the direction of the internal rubber section. The tightening torque for the screws on the Head is 0.78 to 0.88 N•m.</p>	<p>Roller Levers: WLCA2, WL01CA2, WLGCA2, WLMGCA2□ Adjustable Roller Levers: WLCA12, WL01CA12 Adjustable Rod Levers: WLCL, WL01CL Overtravel Models: WLCA□-2N, WL01CA□-2N</p>	<p>One-side Operation for General-purpose and High-precision Switches</p> <p>The output of the Switch will be changed, regardless of which direction the lever is pushed.</p> <p>The output of the Switch will only be changed when the lever is pushed in one direction.</p> <p>Operating Not operating Operating Operating Not operating</p>  <p>Operation in both directions Clockwise operation Counterclockwise operation Operational plunger</p> <p>Cam Direction Changing Procedure for Overtravel, 90° Operation Switches</p> <p>Loosen the cam holder with a coin or screwdriver. Take out the cam from the Switch.</p> <p>Change the direction of the cam as required by your intended operation and then reinstall the cam.</p>  <p>Relationship of cam to operation as observed from the rear of Switch</p> <p>Operation on both sides Operation on one side</p> <p>Operates Operates Operates Does not operate</p> <p>Operation on one side</p> <p>Does not operate Operates</p> <p>Avoid this combination</p> 

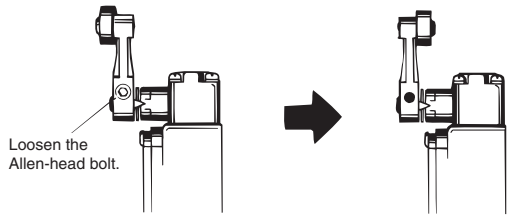
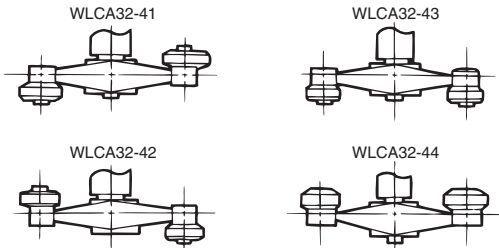
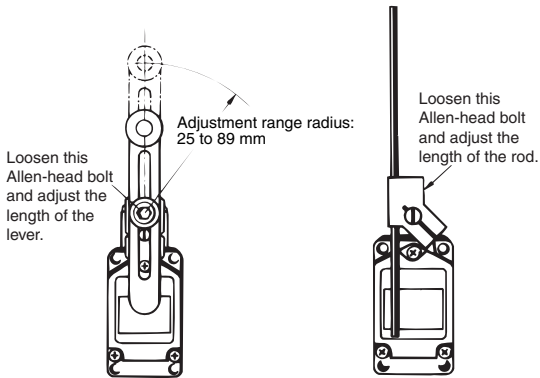
Item	Applicable models and Actuators	Details
<p>Installing the Roller on the Inside By installing the roller lever in the opposite direction, the roller can be installed on the inside. (Set so that operation can be completed within a 180° level range.)</p>	<p>Roller Levers: WLCA□, WL01CA□, WLH□, WLCA□-2, WL01CA□-2, WLMCA2□, WLMH2□, WLMG2□, WLMGCA2□, WLG□, except for the adjustable roller levers. Fork Lever Locks: WLCA32-4□, WL01CA32-4□</p>	 <p>Loosen the Allen-head bolt.</p>
<p>Selecting the Roller Position There are four types of fork lever lock for use depending on the roller position.</p>	<p>Fork Lever Locks: WLCA32-4□, WL01CA32-4□</p>	 <p>WLCA32-41 WLCA32-43 WLCA32-42 WLCA32-44</p> <p>Note: An explanation of the operation of fork lever locks is provided after this table.</p>
<p>Adjusting the Length of the Rod or Lever The length of the rod or lever can be adjusted by loosening the Allen-head bolt.</p>	<p>Adjustable Roller Levers: WLCA12, WL01CA12 etc. Adjustable Rod Levers: WLCL, WL01CL, etc.</p>	<p>WLCA12 etc.</p>  <p>Adjustment range radius: 25 to 89 mm</p> <p>Loosen this Allen-head bolt and adjust the length of the lever.</p> <p>Loosen this Allen-head bolt and adjust the length of the rod.</p>

Operation of Fork Lever Locks

The fork lever lock is configured so that the dog pushes the lever to reverse the output and this reversed state is maintained even after the dog continues on. If the dog then pushes the lever from the opposite direction, the lever will return to its original position.

Example

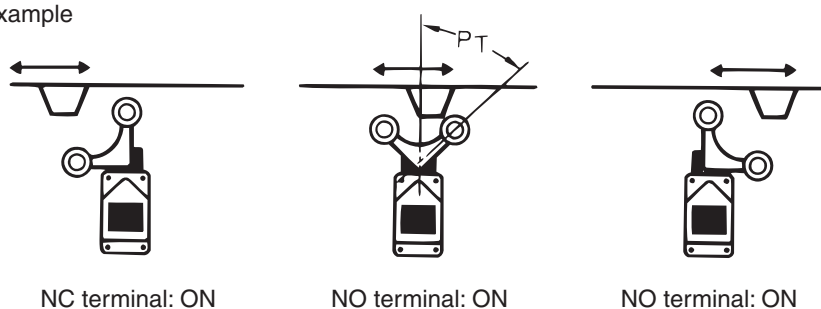

Read and Understand This Catalog

Please read and understand this catalog before purchasing the products. Please consult your OMRON representative if you have any questions or comments.

Warranty and Limitations of Liability

WARRANTY

OMRON's exclusive warranty is that the products are free from defects in materials and workmanship for a period of one year (or other period if specified) from date of sale by OMRON.

OMRON MAKES NO WARRANTY OR REPRESENTATION, EXPRESS OR IMPLIED, REGARDING NON-INFRINGEMENT, MERCHANTABILITY, OR FITNESS FOR PARTICULAR PURPOSE OF THE PRODUCTS. ANY BUYER OR USER ACKNOWLEDGES THAT THE BUYER OR USER ALONE HAS DETERMINED THAT THE PRODUCTS WILL SUITABLY MEET THE REQUIREMENTS OF THEIR INTENDED USE. OMRON DISCLAIMS ALL OTHER WARRANTIES, EXPRESS OR IMPLIED.

LIMITATIONS OF LIABILITY

OMRON SHALL NOT BE RESPONSIBLE FOR SPECIAL, INDIRECT, OR CONSEQUENTIAL DAMAGES, LOSS OF PROFITS OR COMMERCIAL LOSS IN ANY WAY CONNECTED WITH THE PRODUCTS, WHETHER SUCH CLAIM IS BASED ON CONTRACT, WARRANTY, NEGLIGENCE, OR STRICT LIABILITY.

In no event shall the responsibility of OMRON for any act exceed the individual price of the product on which liability is asserted.

IN NO EVENT SHALL OMRON BE RESPONSIBLE FOR WARRANTY, REPAIR, OR OTHER CLAIMS REGARDING THE PRODUCTS UNLESS OMRON'S ANALYSIS CONFIRMS THAT THE PRODUCTS WERE PROPERLY HANDLED, STORED, INSTALLED, AND MAINTAINED AND NOT SUBJECT TO CONTAMINATION, ABUSE, MISUSE, OR INAPPROPRIATE MODIFICATION OR REPAIR.

Application Considerations

SUITABILITY FOR USE

OMRON shall not be responsible for conformity with any standards, codes, or regulations that apply to the combination of products in the customer's application or use of the products.

At the customer's request, OMRON will provide applicable third party certification documents identifying ratings and limitations of use that apply to the products. This information by itself is not sufficient for a complete determination of the suitability of the products in combination with the end product, machine, system, or other application or use.

The following are some examples of applications for which particular attention must be given. This is not intended to be an exhaustive list of all possible uses of the products, nor is it intended to imply that the uses listed may be suitable for the products:

- Outdoor use, uses involving potential chemical contamination or electrical interference, or conditions or uses not described in this catalog.
- Nuclear energy control systems, combustion systems, railroad systems, aviation systems, medical equipment, amusement machines, vehicles, safety equipment, and installations subject to separate industry or government regulations.
- Systems, machines, and equipment that could present a risk to life or property.

Please know and observe all prohibitions of use applicable to the products.

NEVER USE THE PRODUCTS FOR AN APPLICATION INVOLVING SERIOUS RISK TO LIFE OR PROPERTY WITHOUT ENSURING THAT THE SYSTEM AS A WHOLE HAS BEEN DESIGNED TO ADDRESS THE RISKS, AND THAT THE OMRON PRODUCTS ARE PROPERLY RATED AND INSTALLED FOR THE INTENDED USE WITHIN THE OVERALL EQUIPMENT OR SYSTEM.

PROGRAMMABLE PRODUCTS

OMRON shall not be responsible for the user's programming of a programmable product, or any consequence thereof.

Disclaimers

CHANGE IN SPECIFICATIONS

Product specifications and accessories may be changed at any time based on improvements and other reasons.

It is our practice to change model numbers when published ratings or features are changed, or when significant construction changes are made. However, some specifications of the products may be changed without any notice. When in doubt, special model numbers may be assigned to fix or establish key specifications for your application on your request. Please consult with your OMRON representative at any time to confirm actual specifications of purchased products.

DIMENSIONS AND WEIGHTS

Dimensions and weights are nominal and are not to be used for manufacturing purposes, even when tolerances are shown.

PERFORMANCE DATA

Performance data given in this catalog is provided as a guide for the user in determining suitability and does not constitute a warranty. It may represent the result of OMRON's test conditions, and the users must correlate it to actual application requirements. Actual performance is subject to the OMRON Warranty and Limitations of Liability.

ERRORS AND OMISSIONS

The information in this document has been carefully checked and is believed to be accurate; however, no responsibility is assumed for clerical, typographical, or proofreading errors, or omissions.

2011.4

In the interest of product improvement, specifications are subject to change without notice.

OMRON Corporation
Industrial Automation Company

<http://www.ia.omron.com/>

(c)Copyright OMRON Corporation 2011 All Right Reserved.